



ENGINE

Model	ISUZU A-6BG1T
Type	4-cycle water-cooled, direct injection
Aspiration	Turbocharged
No. of cylinders	6
Rated flywheel	99 kW (135 PS) at 1 950 min ⁻¹ (rpm)
horsepower (DIN 6271, net)	
Rated flywheel	98 kW (132 HP) at 1 950 min ⁻¹ (rpm)
horsepower (SAE J1349, net)	
Maximum torque	461 N·m (47 kgf·m, 340 lbf·ft)
	at 1 600 min ⁻¹ (rpm)
Piston displacement	6.494 L (396 in ³)
Bore and stroke	105 mm × 125 mm (4.13" × 4.92")
Batteries	2 × 12 V, 120 AH
Governor	Mechanical, speed control with stepping motor



HYDRAULIC SYSTEM

- Work mode selector
General purpose mode / Grading mode / Precision mode
/ Attachment mode
- Engine speed sensing system

Main pumps	2 variable displacement axial piston pumps
Maximum oil flow	2 × 185 L / min (48.9 US gpm, 40.7 Imp gpm)
Pilot pump	1 gear pump
Max. oil flow	33 L / min. (8.7 US gpm, 7.3 Imp gpm)

Hydraulic Motors

Travel	2 variable displacement axial piston motors
Swing	1 axial piston motor

Relief Valve Settings

Implement circuit	34.3 MPa (350 kgf/cm ² , 4 980 psi)
Swing circuit	30.9 MPa (315 kgf/cm ² , 4 480 psi)
Travel circuit	34.3 MPa (350 kgf/cm ² , 4 980 psi)
Pilot circuit	3.7 MPa (38 kgf/cm ² , 540 psi)
Power boost	36.3 MPa (370 kgf/cm ² , 5 260 psi)

Hydraulic Cylinders

High-strength piston rods and tubes. Cylinder cushion mechanisms provided in all cylinders to absorb shock at stroke ends.

Dimensions

	Qty.	Bore	Rod diameter
Boom	2	120 mm (4.72")	85 mm (3.35")
Arm	1	130 mm (5.12")	95 mm (3.74")
Bucket	1	110 mm (4.33")	75 mm (2.95")

Hydraulic Filters

Hydraulic circuits use high-quality hydraulic filters. A suction filter is incorporated in the suction line, and 10 μm full-flow filters in the return line and swing/travel motor drain lines.



CONTROLS

Pilot controls. Hitachi's original shockless valve and quick warm-up system built in the pilot circuit. Hydraulic warm-up control system for engine and hydraulic oil.

Implement levers	2
Travel levers with pedals	2



UPPERSTRUCTURE

Revolving Frame

Welded sturdy box construction, using heavy-gauge steel plates for ruggedness. D-section frame for resistance to deformation.

Swing Mechanism

Axial piston motor with planetary reduction gear is bathed in oil. Swing circle is single-row, shear-type ball bearing with induction-hardened internal gear. Internal gear and pinion gear are immersed in lubricant. Swing parking brake is spring-set/hydraulic-released disc type.

Swing speed

13.9 min⁻¹ (rpm)

Operator's Cab

Independent roomy cab, 1 005 mm (40") wide by 1 665 mm (66") high, conforming to ISO* Standards. Reinforced glass windows on 4 sides for visibility. Front windows (upper and lower) are openable. Adjustable, reclining seat with armrests; movable with or without control levers.

* International Standardization Organization



UNDERCARRIAGE

Tracks

Tractor-type undercarriage. Welded track frame using selected materials. Side frame welded to track frame. Lubricated track rollers, idlers, and sprockets with floating seals.

Track shoes with triple grousers made of induction-hardened rolled alloy. Flat and triangular shoes are also available. Heat-treated connecting pins with dirt seals. Hydraulic (grease) track adjusters with shock-absorbing recoil springs.

Numbers of Rollers and Shoes on Each Side

Upper rollers	2
Lower rollers	7: EX200-s/EX210H-s
	8: EX200LC-s/EX210LCH-s
Track shoes	46: EX200-s/EX210H-s
	49: EX200LC-s/EX210LCH-s
Track guard	1: EX200-s/EX200LC-s
	2: EX210H-s/EX210LCH-s

Track guard on the EX210H-s and EX210LCH-s are reinforced.

Traction Device

Each track driven by 2-speed axial piston motor through planetary reduction gear for counterrotation of the tracks. Sprockets are replaceable. Parking brake is spring-set/hydraulic-released disc type. Travel shockless relief valve built in travel motor absorbs shocks when stopping travel.

Automatic transmission system: High—Low.

Travel speeds

High: 0 to 5.5 km/h (3.4 mph)

Low: 0 to 3.5 km/h (2.2 mph)

Maximum traction force 169.7 kN (17 300 kgf, 38 100 lbf)

Gradeability 35° (70 %) continuous

WEIGHTS AND GROUND PRESSURE

Equipped with 5.68 m (18'8") boom, 2.91 m (9'7") arm and 0.80 m³ (1.05 yd³: PCSA heaped) bucket.

Shoe type	Shoe width	Operating weight	Ground pressure
Triple grouser	600 mm (24")	18 800 kg (41 500 lb)	42 kPa (0.43 kgf/cm ² , 6.11 psi)
		19 300 kg (42 600 lb)	40 kPa (0.41 kgf/cm ² , 5.83 psi)
	700 mm (28")	19 200 kg (42 300 lb)	37 kPa (0.38 kgf/cm ² , 5.40 psi)
		19 700 kg (43 400 lb)	35 kPa (0.36 kgf/cm ² , 5.12 psi)
	800 mm (31")	19 500 kg (43 000 lb)	33 kPa (0.33 kgf/cm ² , 4.69 psi)
		20 000 kg (44 100 lb)	31 kPa (0.32 kgf/cm ² , 4.55 psi)
Flat	600 mm (24")	19 600 kg (43 200 lb)	44 kPa (0.45 kgf/cm ² , 6.40 psi)
		20 200 kg (44 500 lb)	42 kPa (0.43 kgf/cm ² , 6.11 psi)
Triangular	760 mm (30")	20 000 kg (44 100 lb)	35 kPa (0.36 kgf/cm ² , 5.12 psi)
		20 600 kg (45 400 lb)	33 kPa (0.34 kgf/cm ² , 4.83 psi)
	900 mm (35")	20 500 kg (45 200 lb)	30 kPa (0.31 kgf/cm ² , 4.41 psi)
		21 100 kg (46 500 lb)	29 kPa (0.29 kgf/cm ² , 4.27 psi)

Figures in [] are data on the EX200LC-s.

Weights of the basic machines (including 4 050 kg (8 900 lb), 4 450 kg (9 800 lb) H-type counterweight and triple grouser shoes, excluding front-end attachment, fuel, Hyd. oil, Eng. oil and coolant etc.) are:

EX200-s	14 700 kg (32 400 lb) with 600 mm (24") shoes
EX200LC-s	15 900 kg (35 100 lb) with 800 mm (31") shoes
EX210H-s	15 400 kg (34 000 lb) with 600 mm (24") Reinforced shoes
EX210LCH-s	15 900 kg (35 100 lb) with 600 mm (24") Reinforced shoes

Buckets

Capacity		Width		No. of teeth	Weight	Recommendation								
PCSA heaped	CECE heaped	Without side cutters	With side cutters			EX200-s		EX200LC-s			EX210H-s (LCH)-s			
						2.22 m (7'3") arm	2.91 m (9'7") arm	4.41 m ¹ (14'6") arm	2.22 m (7'3") arm	2.91 m (9'7") arm	4.41 m ¹ (14'6") arm	2.91 m (9'7") H-arm		
0.51 m ³ (0.67 yd ³)	0.45 m ³	720 mm (28")	850 mm (33")	3	520 kg (1 150 lb)	○	○	○	○	○	○	○		
0.80 m ³ (1.05 yd ³)	0.70 m ³	1 030 mm (41")	1 140 mm (45")	5	670 kg (1 480 lb)	○	○	○	○	○	○	○		
0.91 m ³ (1.19 yd ³)	0.80 m ³	1 150 mm (45")	1 280 mm (50")	5	700 kg (1 540 lb)	○	○	○	○	○	○	○		
1.10 m ³ (1.44 yd ³)	0.90 m ³	1 330 mm (52")	1 460 mm (58")	6	760 kg (1 680 lb)	○	○	○	○	○	○	○		
1.20 m ³ (1.57 yd ³)	1.00 m ³	1 450 mm (57")	—	6	670 kg (1 480 lb)	□	—	—	□	—	—	—		
¹ 0.80 m ³ (1.05 yd ³)	0.70 m ³	1 030 mm (41")	1 140 mm (45")	5	770 kg (1 700 lb)	○	○	○	○	○	○	○		
² 0.80 m ³ (1.05 yd ³)	0.70 m ³	1 030 mm (41")	1 140 mm (45")	5	770 kg (1 700 lb)	○	○	○	○	○	○	○		
³ 0.80 m ³ (1.05 yd ³)	0.70 m ³	1 030 mm (41")	1 140 mm (45")	5	770 kg (1 700 lb)	○	○	○	○	○	○	○		
¹ 0.91 m ³ (1.19 yd ³)	0.80 m ³	1 150 mm (45")	1 280 mm (50")	5	810 kg (1 790 lb)	○	○	○	○	○	○	○		
Ripper bucket: 0.60 m ³ (0.78 yd ³ : CECE heaped), Width 800 mm (31")					3	950 kg (2 090 lb)	●	—	—	●	—	—		
One-point ripper					1	550 kg (1 210 lb)	●	—	—	●	—	—		
Clamshell bucket: 0.60 m ³ (0.78 yd ³ : CECE heaped), Width 940 mm (37")					8	1 240 kg (2 730 lb)	○	○	○	○	○	○		
Slope-finishing blade: Width 1 100 mm (43"), length 2 200 mm (87")						690 kg (1 520 lb)	◇	◇	—	◇	—	—		

- ¹ Reinforced bucket
- ² Level-pin-reinforced bucket
- ³ H-bucket
- ⁴ 2.91 m (9'7") arm + 1.50 m (4'11") extension arm

- Suitable for materials with density of 2 000 kg/m³ (3 370 lb/yd³) or less
- Suitable for materials with density of 1 600 kg/m³ (2 700 lb/yd³) or less
- Suitable for materials with density of 1 100 kg/m³ (1 850 yd³) or less
- Heavy-duty service
- ◇ Slope-finishing service
- Not recommended

EX210H-s/EX210LCH-s (Heavy-duty version): Equipped with 5.68 m (18'8") H-boom, 2.91 m (9'7") H-arm, and 0.80 m³ (1.05 yd³: PCSA heaped) H-bucket.

	Shoe width	Operating weight	Ground pressure
EX210H-s	Reinforced Triple grouser 600 mm (24")	19 800 kg (43 700 lb)	44 kPa (0.45 kgf/cm ² , 6.40 psi)
EX210LCH-s	600 mm (24")	20 300 kg (44 800 lb)	42 kPa (0.43 kgf/cm ² , 6.11 psi)

SERVICE REFILL CAPACITIES

	liters	US gal	Imp gal
Fuel tank	310.0	81.9	68.2
Engine coolant	23.0	6.1	5.1
Engine oil	25.0	6.6	5.5
Swing mechanism	8.2	2.2	1.8
Travel final device (each side)	5.5	1.5	1.2
Hydraulic system	200.0	52.8	44.0
Hydraulic tank	135.0	35.7	29.7

BACKHOE ATTACHMENTS

Boom and arms are of welded, box-section design. 5.68 m (18'8") boom, and 2.22 m (7'3"), 2.91 m (9'7") and 4.41 m (14'6")* arms are available. Bucket is of welded steel structure. Side clearance adjust mechanism provided on the bucket joint bracket.

*2.91 m (9'7") arm + 1.50 m (4'11") extension arm

DIMENSIONS

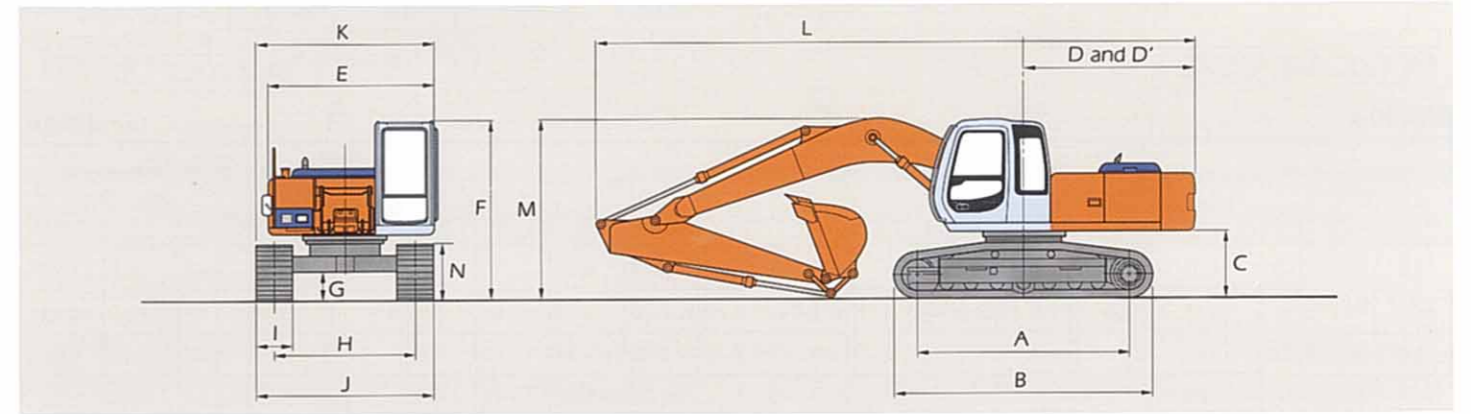

Unit: mm (ft in)

	EX200-s	EX210H-s	EX200LC-s	EX210LCH-s
A Distance between tumbles	3 370 (11'1")		3 660 (12'0")	
B Undercarriage length	4 170 (13'8")		4 460 (14'8")	
*C Counterweight clearance	1 030 (3'5")		1 030 (3'5")	
D Rear-end swing radius	2 750 (9'0")		2 750 (9'0")	
D' Rear-end length	2 720 (8'11")		2 720 (8'11")	
E Overall width of upperstructure	2 710 (8'11")		2 710 (8'11")	
F Overall height of cab	2 870 (9'5")		2 870 (9'5")	
*G Min. ground clearance	450 (1'6")		450 (1'6")	
H Track gauge	2 200 (7'3")		2 390 (7'10")	
I Track shoe width	G 600 (24")		G 800 (31")	G 600 (24")
J Undercarriage width	2 800 (9'2")		3 190 (10'6")	2 990 (9'10")
K Overall width	2 860 (9'5")		3 190 (10'6")	2 990 (9'10")
L Overall length				
With 2.22 m (7'3") arm	9 620 (31'7")		9 620 (31'7")	
With 2.91 m (9'7") arm	9 500 (31'2")	**9 500 (31'2")	9 500 (31'2")	**9 500 (31'2")
With 4.41 m (14'6") arm	9 460 (31'0")		9 460 (31'0")	
M Overall height of boom				
With 2.22 m (7'3") arm	3 090 (10'2")		3 090 (10'2")	
With 2.91 m (9'7") arm	2 970 (9'9")	**2 970 (9'9")	2 970 (9'9")	**2 970 (9'9")
With 4.41 m (14'6") arm	3 550 (11'8")		3 550 (11'8")	
N Track height				
With triple grouser shoes	910 (3'0")	910 (3'0")	910 (3'0")	910 (3'0")

- *Excluding track shoe lug.
- **Equipped with H-Front
- G: Triple grouser shoe
- T: Triangular shoe

WORKING RANGES

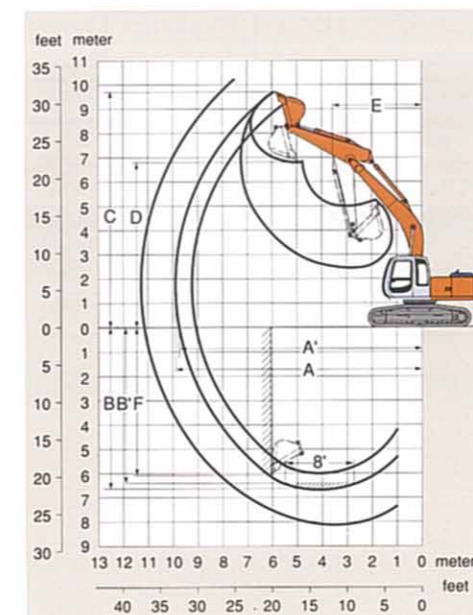

Arm length	EX200-s / EX200LC-s			EX210H-s/EX210LCH-s
	2.22 m (7'3")	2.91 m (9'7")	4.41 m (14'6")*	5.68 m (18'8") H-boom 2.91 m (9'7") H-arm
A Max. digging reach	9 250 (30'4")	9 910 (32'6")	11 260 (36'11")	9 910 (32'6")
A' Max. digging reach (on ground)	9 080 (29'9")	9 750 (32'0")	11 100 (36'5")	9 750 (32'0")
B Max. digging depth	5 980 (19'7")	6 670 (21'11")	8 160 (26'9")	6 670 (21'11")
B' Max. digging depth (8' level)	5 740 (18'10")	6 490 (21'4")	8 030 (26'4")	6 490 (21'4")
C Max. cutting height	9 170 (30'1")	9 600 (31'6")	10 220 (33'6")	9 600 (31'6")
D Max. dumping height	6 390 (21'0")	6 780 (22'3")	7 410 (24'4")	6 780 (22'3")
E Min. swing radius	3 530 (11'7")	3 540 (11'7")	3 540 (11'7")	3 540 (11'7")
F Max. vertical wall	5 140 (16'10")	6 050 (19'10")	7 540 (24'9")	6 050 (19'10")
Bucket digging force**	134 kN (13 700 kgf, 30 200 lbf)			
	120 kN (12 200 kgf, 26 900 lbf)			
Arm crowd force**	127 kN (12 900 kgf, 28 400 lbf)			
	99 kN (10 100 kgf, 22 300 lbf)			
SAE: PCSA	73 kN (7 400 kgf, 16 300 lbf)			
	99 kN (10 100 kgf, 22 300 lbf)			
SAE: PCSA	121 kN (12 300 kgf, 17 100 lbf)			
	94 kN (9 600 kgf, 21 200 lbf)			
SAE: PCSA	71 kN (7 200 kgf, 15 900 lbf)			
	94 kN (9 600 kgf, 21 200 lbf)			

Excluding track shoe lug *2.91 m (9'6") arm + 1.50 m (4'11") extension arm **At power boost

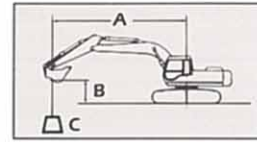

A: Load radius
B: Load point height
C: Lifting capacity

METRIC MEASURE

EX200-5 Rating over-side or 360 degrees Rating over-front Unit: 1 000 kg

Conditions	Load point height	Load radius												At max. reach		
		3 m		4 m		5 m		6 m		7 m		8 m		meter	meter	meter
Boom 5.68 m Arm 2.22 m Bucket PCSA: 0.80 m ³ CECE: 0.70 m ³ Shoe 600 mm	6 m							3.92	* 4.22					2.45	* 3.26	7.85
	4 m			* 6.18	* 6.18	5.09	* 5.23	3.76	* 4.72	2.87	* 4.46			1.95	3.15	8.67
	2 m					4.56	* 7.21	3.46	5.58	2.70	4.35	2.14	3.49	1.78	2.93	8.91
	0 (Ground)					4.24	7.12	3.23	5.33	2.55	4.19	2.06	3.40	1.84	3.05	8.60
	-2 m			6.00	*10.43	4.20	7.07	3.17	5.26	2.51	4.15			2.23	3.65	7.69
-4 m	10.21	*10.46	6.18	* 8.71	4.33	* 7.16	3.30	5.40								
Boom 5.68 m Arm 2.91 m Bucket PCSA: 0.80 m ³ CECE: 0.70 m ³ Shoe 600 mm	6 m							* 3.50	* 3.50	3.01	* 3.30			* 1.95	* 1.95	8.61
	4 m					* 4.41	* 4.41	3.84	* 4.12	2.92	* 3.94	2.26	* 3.50	1.68	* 1.96	9.36
	2 m			6.56	* 8.61	4.69	* 6.45	3.52	* 5.35	2.73	4.38	2.15	3.50	1.54	* 2.09	9.57
	0 (Ground)			5.97	* 7.82	4.27	7.16	3.24	5.35	2.54	4.18	2.03	3.37	1.57	* 2.39	9.29
	-2 m	* 7.12	* 7.12	5.90	10.39	4.14	7.01	3.12	5.21	2.45	4.09	1.99	3.32	1.85	* 2.99	8.46
-4 m	9.95	*12.11	6.03	* 9.61	4.21	7.09	3.17	5.26	2.52	4.16						

EX200LC-5 Unit: 1 000 kg

Conditions	Load point height	Load radius												At max. reach		
		3 m		4 m		5 m		6 m		7 m		8 m		meter	meter	meter
Boom 5.68 m Arm 2.22 m Bucket PCSA: 0.80 m ³ CECE: 0.70 m ³ Shoe 800 mm	6 m							* 4.22	* 4.22					2.86	* 3.26	7.85
	4 m			* 6.18	* 6.18	* 5.23	* 5.23	4.35	* 4.72	3.35	* 4.46			2.30	* 3.29	8.67
	2 m					5.23	* 7.21	4.05	* 5.86	3.17	* 5.10	2.53	4.16	2.12	3.51	8.91
	0 (Ground)					5.00	* 8.46	3.81	6.40	3.02	5.02	2.45	4.07	2.20	3.66	8.60
	-2 m			6.98	*10.43	4.96	* 8.44	3.75	6.33	2.98	4.97			2.64	4.37	7.69
-4 m	*10.46	*10.46	7.29	* 8.71	5.09	* 7.16	3.88	* 5.73								
Boom 5.68 m Arm 2.91 m Bucket PCSA: 0.80 m ³ CECE: 0.70 m ³ Shoe 800 mm	6 m							* 3.50	* 3.50	* 3.30	* 3.30			* 1.95	* 1.95	8.61
	4 m					* 4.41	* 4.41	* 4.12	* 4.12	3.40	* 3.94	2.65	* 3.50	* 1.96	* 1.96	9.36
	2 m			7.68	* 8.61	5.46	* 6.45	4.11	* 5.35	3.20	* 4.70	2.54	4.18	1.85	* 2.09	9.57
	0 (Ground)			7.07	* 7.82	5.03	* 8.09	3.82	6.42	3.01	5.01	2.42	4.05	1.90	* 2.39	9.29
	-2 m	* 7.12	* 7.12	7.00	*10.84	4.90	8.50	3.70	6.28	2.92	4.92	2.38	4.00	2.21	* 2.99	8.46
-4 m	11.91	*12.11	7.14	* 9.61	4.97	* 7.76	3.75	6.33	2.99	4.99						

Notes: 1. Ratings are based on SAE J1097.
2. Lifting capacity of the EX Series does not exceed 75% of tipping load with the machine on firm, level ground or 87% full hydraulic capacity.
3. The load point is a hook (not standard equipment) located on the back of the bucket.
4. *Indicates load limited by hydraulic capacity.

METRIC MEASURE

EX210H-5 Rating over-side or 360 degrees Rating over-front Unit: 1 000 kg

Conditions	Load point height	Load radius												At max. reach								
		3 m		4 m		5 m		6 m		7 m		8 m		meter	meter	meter						
Boom 5.68 m H-boom Arm 2.91 m H-arm Bucket PCSA: 0.80 m ³ CECE: 0.70 m ³ H-bucket Shoe 600 mm Reinforced type	6 m													* 3.35	* 3.35	3.13	* 3.18			* 1.84	* 1.84	8.61
	4 m									* 4.26	* 4.26	* 3.96	* 3.96	3.05	* 3.77	2.34	* 3.37	1.72	* 1.84			9.36
	2 m									6.93	* 8.42	4.93	* 6.27	3.69	* 5.17	2.84	* 4.52	2.22	3.64	1.57	* 1.98	9.57
	0 (Ground)									6.31	* 7.65	4.49	7.54	3.39	5.61	2.65	4.37	2.10	3.51	1.62	* 2.28	9.29
	-2 m			* 6.95	* 6.95	6.24	*10.62	4.36	7.38	3.27	5.47	2.55	4.27	2.05	3.46	1.91	* 2.87					8.46
-4 m	10.56	*11.88	6.37	* 9.39	4.43	7.46	3.32	5.52	2.62	4.35												

EX210LCH-5 Unit: 1 000 kg

Conditions	Load point height	Load radius												At max. reach								
		3 m		4 m		5 m		6 m		7 m		8 m		meter	meter	meter						
Boom 5.68 m H-boom Arm 2.91 m H-arm Bucket PCSA: 0.80 m ³ CECE: 0.70 m ³ H-bucket Shoe 600 mm Reinforced type	6 m													* 3.35	* 3.35	* 3.18	* 3.18			* 1.84	* 1.84	8.61
	4 m									* 4.26	* 4.26	* 3.96	* 3.96	3.42	* 3.77	2.65	* 3.37	* 1.84	* 1.84			9.36
	2 m									7.85	* 8.42	5.56	* 6.27	4.15	* 5.17	3.21	* 4.52	2.53	* 4.12	1.82	* 1.98	9.57
	0 (Ground)									7.21	* 7.65	5.11	* 7.89	3.86	* 6.28	3.02	5.05	2.41	4.06	1.87	* 2.28	9.29
	-2 m			* 6.96	* 6.96	7.13	*10.62	4.97	* 8.31	3.73	6.35	2.92	4.95	2.36	4.01	2.19	* 2.87					8.46
-4 m	*11.87	*11.87	7.28	* 9.39	5.04	* 7.56	3.78	* 6.14	2.99	* 4.88												

Notes: 1. Ratings are based on SAE J1097.
2. Lifting capacity of the EX Series does not exceed 75% of tipping load with the machine on firm, level ground or 87% full hydraulic capacity.
3. The load point is a hook (not standard equipment) located on the back of the bucket.
4. *Indicates load limited by hydraulic capacity.



STANDARD EQUIPMENT

Standard equipment may vary by country, so please consult your Hitachi dealer for details.

ENGINE

- HP mode control
- E mode control
- 40 A alternator
- Dry-type air filter with evacuator valve (with safety element)
- Cartridge-type engine oil filter
- Cartridge-type engine oil bypass filter
- Cartridge type fuel filter
- Air cleaner double element
- Radiator and oil cooler with dust protective net
- Radiator reserve tank
- Fan guard
- Isolation-mounted engine
- Auto-idle system

HYDRAULIC SYSTEM

- Work mode selector
- Engine speed sensing system
- E-P control system
- Quick warm-up system for pilot circuit
- Shockless valve in pilot circuit
- Boom-arm anti-drift valve
- Control valve with main relief valve
- Extra port for control valve
- Suction filter
- Full-flow filter
- Pilot filter

CAB

All-weather sound-suppressed steel cab equipped with reinforced, tinted (bronze color) glass windows, 6 fluid-filled elastic mounts, openable front windows-upper, and lower and left side windows with intermittent windshield retractable wipers, front window washer, adjustable reclining seat with adjustable armrests, footrest, electric double horn, auto-tuning radio with digital clock, auto-idle switch, seat belt, cigarette lighter, ashtray, parcel pocket, glove compartment, floor mat, heater, and pilot control shut-off lever.

MONITOR SYSTEM

- Meters:
 - Hourmeter, engine coolant temperature gauge and fuel meter.
- Warning lamps:
 - Alternator charge, engine oil pressure, engine overheat, air cleaner clog and minimum fuel level.
- Pilot lamps:
 - Engine preheat, engine oil level, engine coolant level and hydraulic oil level.
- Alarm buzzers:
 - Engine oil pressure and engine overheat

LIGHTS

- 2 working lights

UPPERSTRUCTURE

- Undercover
- 4 050 kg (8 930 lb) counterweight
- Fuel level float
- Hydraulic oil level gauge
- Tool box
- Utility space
- Rearview mirror (right side)
- Swing parking brake

UNDERCARRIAGE

- Travel parking brake
- Travel motor covers
- Track guards and hydraulic track adjuster
- Bolt-on sprocket
- Upper rollers and lower rollers
- Reinforced track links with pin seals
- 600 mm (24") triple grouser shoes.

FRONT ATTACHMENTS

- HN bushing (Specified country only)
- Bucket clearance adjust mechanism
- Monolithically cast bucket link A
- Centralized lubrication system

- Dirt seals on all bucket pins
- 2.91 m (9'7") arm
- 0.80 m³ (1.05 yd³: PCSA heaped) bucket

MISCELLANEOUS

- Standard tool kit
- Lockable machine covers
- Lockable fuel filling cap
- Skid-resistant tapes and handrails.

EX210H / EX210LCH (Heavy-duty version)

- H-boom 5.68 m (18'8") and H-arm 2.91 m (9'7")
- 0.80 m³ (1.05 yd³: PCSA heaped) H-bucket
- Reinforced bucket link B
- Front glass lower guard
- Reinforced undercover
- 4 450 kg (9 800 lb) H-counterweight
- 600 mm (24") reinforced triple grouser shoes
- H-track guard
- Reinforced side step (bolt on type)



OPTIONAL EQUIPMENT

Optional equipment may vary by country, so please consult your Hitachi dealer for details.

- Air conditioner
- Suspension seat
- AM-FM radio
- Hose rupture valves
- Electric fuel refilling pump
- Swing motion alarm device with lamps
- Travel motion alarm device
- Additional pump
- Piping kit for extra valve port
- Additional valve with piping kit
- PTO valve with piping kit
- Auto-lubrication system
- Pre-cleaner
- Tropical cover
- H-boom 5.68 m (18'8")
- H-arm 2.91 m (9'7")
- 0.80 m³ (1.05 yd³: PCSA heaped) H-bucket
- Front glass lower guard
- Reinforced undercover for upperstructure
- 4 450 kg (9 800 lb) H-counterweight
- 600 mm (24") reinforced triple grouser shoes
- H-track guard
- 0.80 m³ (1.05 yd³: PCSA heaped) Level pin-reinforced bucket
- Full track guard
- Ripper bucket for ripping and loading hardpan
- One point ripper for ripping hardpan
- Clamshell bucket for deep vertical excavations such as manholes, pilings, footings, etc.
- Slope finishing blade for slope finishing jobs. . . scraping up or down, compacting, grading etc.

These specifications are subject to change without notice. Illustrations and photos show the standard models, and may or may not include optional equipment, accessories, and all standard equipment, with some differences in color and features.



Hitachi Construction Machinery Co., Ltd.

Head Office: Nippon Bldg., 6-2, 2-chome, Ohtemachi, Chiyoda-ku, Tokyo 100-0004, Japan

Telephone: Tokyo (03) 3245-6390

Facsimile: Tokyo (03) 3246-2609