

# SPECIFICATIONS



## ENGINE

Model .....	Nissan A-BD30
Type .....	4-cycle water-cooled, direct injection
Rated flywheel .....	41 kW (55 PS) at 2 200 min <sup>-1</sup> (rpm)
horsepower (DIN 6271, net)	
Rated flywheel .....	40 kW (54 HP) at 2 200 min <sup>-1</sup> (rpm)
horsepower (SAE J1349, net)	
Maximum torque .....	181 N·m (18.5 kgf·m, 134 lbf·ft)
at 1 500 min <sup>-1</sup> (rpm)	
Piston displacement .....	2.953 L (180 in <sup>3</sup> )
Bore and stroke .....	96 mm × 102 mm (3.8" × 4.0")
Batteries .....	2 × 12 V, 52 AH
Governor .....	Mechanical all-speed by stepping motor



## HYDRAULIC SYSTEM

Hitachi's ETS (Electronic Total control System) can achieve maximum job efficiency and reduce fuel consumption /noise.

- E-P Control (Computer-aided Engine-Pump Control) System
- OHS (Optimum Hydraulic System) assures fully independent and combined operations
- FPS (Fuel-saving Pump System)
- Auto-idling system
- High-pressure 3-speed travel system for high traction force and travel speed

Main pumps .....	2 variable displacement axial piston pumps
Maximum oil flow .....	2 × 94.6 L/min (25.0 US gpm, 20.8 Imp gpm)
Pilot pump .....	1 gear pump
Maximum oil flow .....	23.5 L/min (6.2 US gpm, 5.2 Imp gpm)

### Relief Valve Settings

Implement circuit .....	26.0 MPa (265 kgf/cm <sup>2</sup> , 3 770 psi)
Swing circuit .....	26.0 MPa (265 kgf/cm <sup>2</sup> , 3 770 psi)
Travel circuit .....	27.5 MPa (280 kgf/cm <sup>2</sup> , 3 980 psi)
Pilot circuit .....	3.4 MPa (35 kgf/cm <sup>2</sup> , 550 psi)

### Hydraulic Cylinders

High-strength piston rods and tubes are used. Cylinder cushion mechanisms are provided for all cylinders to absorb shock when pistons reach their stroke ends.

### Dimensions

	Quan.	Bore	Rod diameter
Boom	1	115 mm (4.53")	65 mm (2.56")
Arm	1	95 mm (3.74")	60 mm (2.36")
Bucket	1	85 mm (3.35")	55 mm (2.17")

### Hydraulic Filters

Hydraulic circuits use high-quality hydraulic filters. A suction filter is incorporated in suction line, and a 10µm full-flow filter in return line and swing/travel motor drain lines.



## CONTROLS

Pilot controls. Hitachi's original shockless valve and quick warm-up system built in the pilot circuit. Hydraulic warm-up control system for engine and hydraulic oil. Multi selection lever with rotary valve is optionally available for selection of control lever direction.

Implement levers .....	2
Travel levers .....	2



## UPPERSTRUCTURE

### Revolving Frame

Welded high-sturdy box construction, using heavy-gauge steel plates for ruggedness. D-section frame for resistance to deformation.

### Swing Mechanism

Axial piston motor with planetary reduction gear is bathed in oil. Swing circle is single-row, shear-type ball bearing with induction-hardened internal gear. Internal gear and pinion gear immersed in lubricant. Swing parking brake is spring-set/hydraulic-released disc type. Swing cushion valve built in swing motor absorbs shocks when stopping swing, ensuring smooth stops.

Swing speed .....	15.0 min <sup>-1</sup> (rpm)
-------------------	------------------------------

### Operator's Cab

Independent roomy cab, 940 mm (37") wide by 1 620 mm (64") high, conforming to ISO\* Standards. Reinforced glass windows on 4 sides for visibility. Front windows (upper and lower), fully openable, is storable in the cab. Adjustable reclining seat with armrests; movable with or without control levers and monitor panel.

\* International Standard Organization



## UNDERCARRIAGE

### Tracks

Tractor-type undercarriage. Welded track frame, using carefully selected materials. Side frame welded to the track frame. Lubricated track rollers, idlers, and sprockets with floating seals. Track shoes with triple grousers made of induction-hardened rolled alloy. Rubber, flat and triangular shoes also available. Heat-treated connecting pins with dirt seals. Hydraulic (grease) track adjusters with shock-absorbing recoil springs.

### Numbers of Rollers and Shoes on Each Side

Upper roller .....	1
Lower rollers .....	5
Track shoes .....	37 EX60-3 39 EX60LC-3

### Traction Device

Each track driven by a high-torque, axial piston motor through planetary reduction gears for counterrotation of the tracks. Sprockets are for replaceable. Parking brake is spring-set/hydraulic-released disc type. Travel shockless relief valve built in travel motor absorbs shocks when stopping travel.

Travel speeds .....	High: 0 to 5.0 km/h (3.1 mph)
	Medium: 0 to 3.3 km/h (2.0 mph)
	Low: 0 to 2.5 km/h (1.6 mph)

Maximum traction force .....	48.1 kN (4 900 kgf, 10 800 lbf)
Gradeability .....	35° (70 %) continuous



## WEIGHTS AND GROUND PRESSURE

### EX60-3:

Equipped with 3.72 m (12'2") boom, 1.62 m (5'4") arm, and 0.28 m<sup>3</sup> (0.37 yd<sup>3</sup>; PCSA heaped) bucket.

Shoe type	Shoe width	Operating weight	Ground pressure
Triple grouser	450 mm (18")	6 300 kg (13 900 lb)	30.4 kPa (0.31 kgf/cm <sup>2</sup> , 4.41 psi)
		6 440 kg (14 200 lb)	28.4 kPa (0.29 kgf/cm <sup>2</sup> , 4.12 psi)
	600 mm (24")	6 470 kg (14 300 lb)	23.5 kPa (0.24 kgf/cm <sup>2</sup> , 3.41 psi)
		6 620 kg (14 600 lb)	22.6 kPa (0.23 kgf/cm <sup>2</sup> , 3.27 psi)
Rubber type	450 mm (18")	6 180 kg (13 500 lb)	29.4 kPa (0.30 kgf/cm <sup>2</sup> , 4.27 psi)
		6 310 kg (13 900 lb)	27.5 kPa (0.28 kgf/cm <sup>2</sup> , 3.98 psi)
Triangular type	500 mm (20")	6 480 kg (14 300 lb)	27.5 kPa (0.28 kgf/cm <sup>2</sup> , 3.98 psi)
		6 630 kg (14 600 lb)	26.5 kPa (0.27 kgf/cm <sup>2</sup> , 3.84 psi)
	700 mm (28")	6 590 kg (14 500 lb)	20.6 kPa (0.21 kgf/cm <sup>2</sup> , 2.99 psi)
		6 750 kg (14 900 lb)	19.6 kPa (0.20 kgf/cm <sup>2</sup> , 2.84 psi)
Flat type	450 mm (18")	6 500 kg (14 300 lb)	30.4 kPa (0.31 kgf/cm <sup>2</sup> , 4.41 psi)
		6 610 kg (14 600 lb)	29.4 kPa (0.30 kgf/cm <sup>2</sup> , 4.27 psi)

Figures in      are data on the EX60LC-3.

Weights of the basic machines (including 650 kg: 1 430 lb counterweight and triple grouser shoes excluding front-end attachment) are:

EX60-3 ..... 5 020 kg (11 100 lb) with 450 mm (18") shoes  
EX60LC-3 ..... 5 130 kg (11 300 lb) with 450 mm (18") shoes

## SERVICE REFILL CAPACITIES

	liters	US gal	Imp gal
Fuel tank	135.0	35.7	29.7
Engine coolant	10.0	2.6	2.2
Engine oil	12.5	3.3	2.7
Swing mechanism	1.8	0.48	0.40
Travel final device (each side)	3.0	0.79	0.66
Hydraulic system	90.0	23.8	19.8
Hydraulic tank	42.0	11.1	9.2

## Buckets

Capacity		Width		No. of teeth	Weight	Recommendation					
PCSA heaped	CECE heaped	Without side cutters	With side cutters			EX60-3/EX60LC-3		EX60-3/EX60LC-3 with Rubber crawler		EX60-3/EX60LC-3 with Off-set front	
						1.62 m (5'4") arm	2.12 m (6'11") arm	1.62 m (5'4") arm	2.12 m (6'11") arm		
0.11 m <sup>3</sup> (0.14 yd <sup>3</sup> )	0.10 m <sup>3</sup>	360 mm (14")	450 mm (18")	3	140 kg (310 lb)	⊙	⊙	⊙	⊙	⊙	
0.24 m <sup>3</sup> (0.31 yd <sup>3</sup> )	0.20 m <sup>3</sup>	560 mm (22")	650 mm (26")	3	180 kg (400 lb)	⊙	⊙	⊙	⊙	⊙	
0.28 m <sup>3</sup> (0.37 yd <sup>3</sup> )	0.25 m <sup>3</sup>	660 mm (26")	750 mm (30")	4	200 kg (440 lb)	⊙	⊙(⊙)* <sup>2</sup>	⊙	⊙(⊙)* <sup>2</sup>	⊙	
0.34 m <sup>3</sup> (0.44 yd <sup>3</sup> )	0.30 m <sup>3</sup>	770 mm (30")	860 mm (34")	5	220 kg (490 lb)	⊙(⊙)	—	⊙(⊙)	—	—	
*0.28 m <sup>3</sup> (0.37 yd <sup>3</sup> )	0.25 m <sup>3</sup>	660 mm (26")	750 mm (30")	4	240 kg (530 lb)	⊙	⊙(⊙)* <sup>2</sup>	⊙	⊙(⊙)* <sup>2</sup>	⊙* <sup>2</sup>	
V-shaped bucket 0.20 m <sup>3</sup> (0.26 yd <sup>3</sup> ; CECE heaped)					2	190 kg (420 lb)	⊙	⊙	⊙	⊙	—
Slope-finishing blade: Width-750 mm (30"). Length-1 500 mm (59")						250 kg (550 lb)	◇	◇	◇	◇	—

\*1 Reinforced bucket

\*2 With 600 mm (24")/700 mm (28") shoes only

⊙ Suitable for materials with density of 2 000 kg/m<sup>3</sup> (3 370 lb/yd<sup>3</sup>) or less

○ Suitable for materials with density of 1 600 kg/m<sup>3</sup> (2 700 lb/yd<sup>3</sup>) or less

◇ Slope finishing service

— Not recommended

### EX60-3 with Off-set front:

Equipped with 1.62 m (5'4") arm, and 0.28 m<sup>3</sup> (0.37 yd<sup>3</sup>; PCSA heaped) bucket.

Shoe type	Shoe width	Operating weight	Ground pressure
Triple grouser	450 mm (18")	6 820 kg (15 000 lb)	32.4 kPa (0.33 kgf/cm <sup>2</sup> , 4.69 psi)
		6 930 kg (15 300 lb)	31.4 kPa (0.32 kgf/cm <sup>2</sup> , 4.55 psi)
	600 mm (24")	6 990 kg (15 400 lb)	25.5 kPa (0.26 kgf/cm <sup>2</sup> , 3.70 psi)
		7 110 kg (15 700 lb)	23.5 kPa (0.24 kgf/cm <sup>2</sup> , 3.41 psi)
Rubber with dozer blade	450 mm (18")	7 210 kg (15 900 lb)	34.3 kPa (0.35 kgf/cm <sup>2</sup> , 4.98 psi)
		7 320 kg (16 100 lb)	32.4 kPa (0.33 kgf/cm <sup>2</sup> , 4.69 psi)
Triangular type	500 mm (20")	7 000 kg (15 400 lb)	30.4 kPa (0.31 kgf/cm <sup>2</sup> , 4.41 psi)
		7 120 kg (15 700 lb)	28.4 kPa (0.29 kgf/cm <sup>2</sup> , 4.12 psi)
	700 mm (28")	7 110 kg (15 700 lb)	21.6 kPa (0.22 kgf/cm <sup>2</sup> , 3.13 psi)
		7 240 kg (16 000 lb)	20.6 kPa (0.21 kgf/cm <sup>2</sup> , 2.99 psi)
Flat type	450 mm (18")	6 980 kg (15 400 lb)	33.3 kPa (0.34 kgf/cm <sup>2</sup> , 4.83 psi)
		7 100 kg (15 700 lb)	31.4 kPa (0.32 kgf/cm <sup>2</sup> , 4.55 psi)

Figures in      are data on the EX60LC-3.

Weights of the basic machines (including 700 kg: 1 540 lb counterweight and triple grouser shoes excluding front-end attachment) are:

EX60-3 ..... 5 070 kg (11 200 lb) with 450 mm (18") shoes  
EX60LC-3 ..... 5 180 kg (11 400 lb) with 450 mm (18") shoes

## BACKHOE ATTACHMENTS

Boom and arms are of all-welded, low-stress, full box-section design. 3.72 m (12'2") boom, 1.62 m (5'4") and 2.12 m (6'11") arms are available.

Bucket is of all-welded, high-strength steel structure. Side clearance adjust mechanism provided on the bucket joint bracket.



## DIMENSIONS

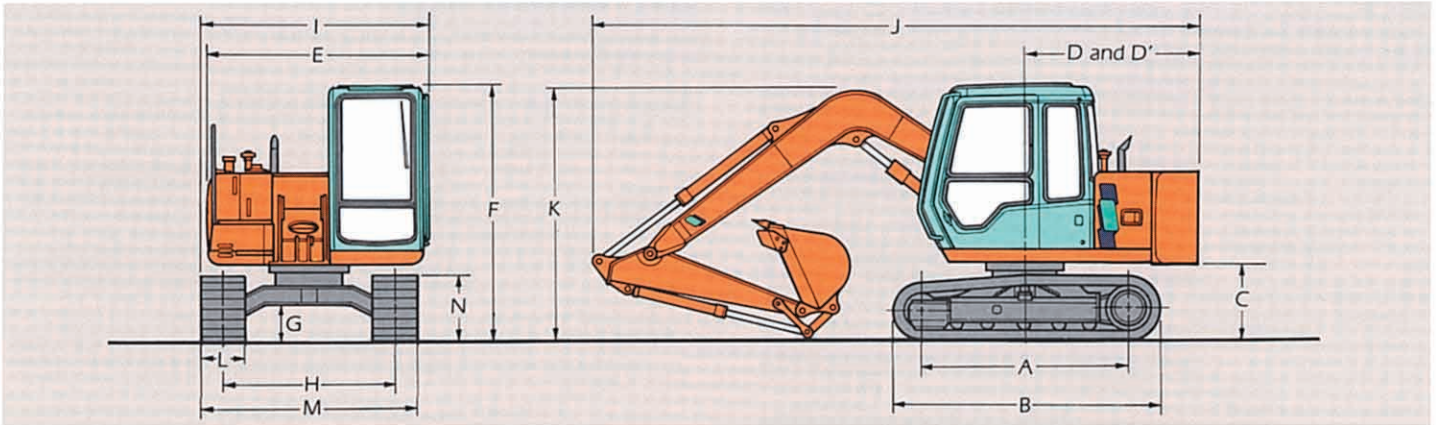

	EX60-3/EX60LC-3		EX60-3/EX60LC-3 with Rubber crawler	
A Distance between tumbler	STD 2 090 mm (6'10")	LC 2 245 mm (7'4")	STD 2 110 mm (6'11")	LC 2 280 mm (7'6")
B Undercarriage length	STD 2 700 mm (8'10")	LC 2 855 mm (9'4")	STD 2 710 mm (8'11")	LC 2 865 mm (9'5")
*C Counterweight clearance	760 mm (2'6")		780 mm (2'7")	
D Rear-end swing radius	1 750 mm (5'9")		1 750 mm (5'9")	
D' Rear-end; length	1 750 mm (5'9")		1 750 mm (5'9")	
E Overall width of upperstructure	2 205 mm (7'3")		2 205 mm (7'3")	
F Overall height of cab	2 570 mm (8'5")		2 570 mm (8'5")	
*G Min. ground clearance	360 mm (1'2")		380 mm (1'3")	
H Track gauge	STD 1 700 mm (5'7")	LC 1 850 mm (6'1")	STD 1 700 mm (5'7")	LC 1 850 mm (6'1")
I Overall width	STD 2 280 mm (7'6")	LC 2 355 mm (7'9")	STD 2 280 mm (7'6")	LC 2 355 mm (7'9")
J Overall length				
With 1.62 m (5'4") arm	6 080 mm (19'11")		6 080 mm (19'11")	
With 2.12 m (6'11") arm	6 120 mm (20'1")		6 120 mm (20'1")	
K Overall height of boom				
With 1.62 m (5'4") arm	2 540 mm (8'4")		2 540 mm (8'4")	
With 2.12 m (6'11") arm	2 690 mm (8'10")		2 690 mm (8'10")	
L Track shoe width	G: 450 mm (18")      G: 600 mm (24")		R: 450 mm (18")	
M Undercarriage width	STD 2 150 mm (7'1")	2 300 mm (7'7")	STD 2 150 mm (7'1")	2 300 mm (7'7")
N Track height	670 mm (2'2") with triple grouser shoe		670 mm (2'2") with rubber crawler	

\*Excluding track shoe lug.  
(Except the rubber crawler)

G: Triple grouser shoe

R: Rubber crawler

## WORKING RANGES

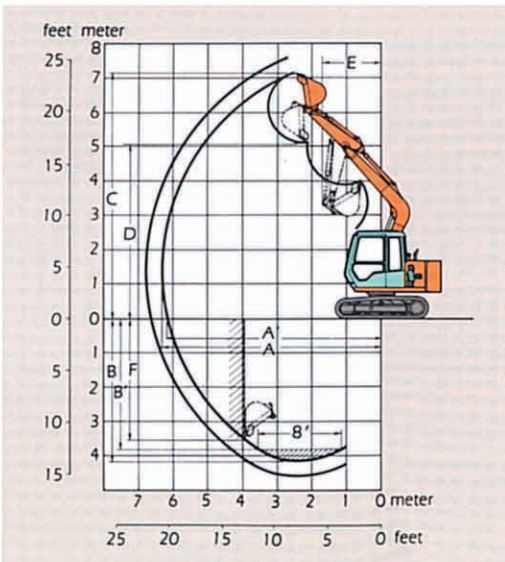

	EX60-3/EX60LC-3		EX60-3/EX60LC-3 with Rubber crawler	
	1.62 m (5'4")	2.12 m (6'11")	1.62 m (5'4")	2.12 m (6'11")
<b>Arm length</b>	1.62 m (5'4")	2.12 m (6'11")	1.62 m (5'4")	2.12 m (6'11")
A Max. digging reach	6 310 mm (20'8")	6 800 mm (22'4")	6 310 mm (20'8")	6 800 mm (22'4")
A' Max. digging reach (on ground)	6 160 mm (20'3")	6 660 mm (21'10")	6 160 mm (20'3")	6 660 mm (21'10")
B Max. digging depth	4 150 mm (13'7")	4 660 mm (15'3")	4 130 mm (13'7")	4 640 mm (15'3")
B' Max. digging depth (8' level)	3 800 mm (12'6")	4 370 mm (14'4")	3 780 mm (12'5")	4 350 mm (14'3")
C Max. cutting height	7 150 mm (23'5")	7 550 mm (24'9")	7 170 mm (23'6")	7 570 mm (24'10")
D Max. dumping height	5 070 mm (16'8")	5 470 mm (17'11")	5 090 mm (16'8")	5 490 mm (18'0")
E Min. swing radius	1 700 mm (5'7")	2 060 mm (6'9")	1 700 mm (5'7")	2 060 mm (6'9")
F Max. vertical wall	3 500 mm (11'6")	4 060 mm (13'4")	3 480 mm (11'5")	4 040 mm (13'3")
Bucket digging force	47.1 kN (4 800 kgf, 10 600 lbf)	47.1 kN (4 800 kgf, 10 600 lbf)	47.1 kN (4 800 kgf, 10 600 lbf)	47.1 kN (4 800 kgf, 10 600 lbf)
Arm crowd force	36.3 kN (3 700 kgf, 8 200 lbf)	31.4 kN (3 200 kgf, 7 100 lbf)	36.3 kN (3 700 kgf, 8 200 lbf)	31.4 kN (3 200 kgf, 7 100 lbf)



## DIMENSIONS

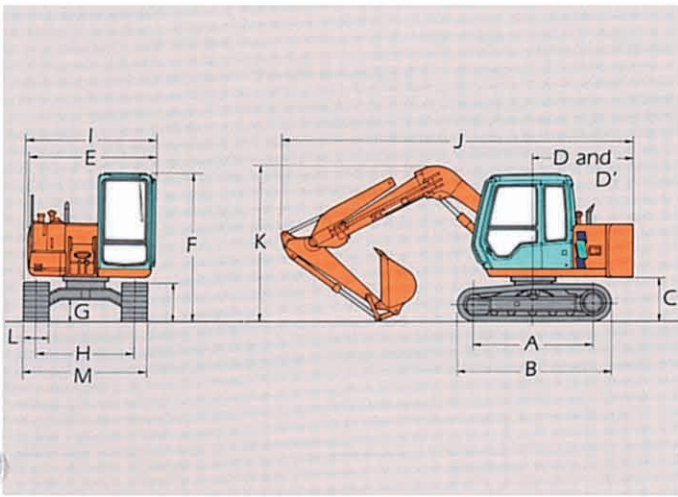

		EX60-3/EX60LC-3 with Off-set front	
A	Distance between tumbler	STD 2 090 mm (6'10")	LC 2 245 mm (7'4")
B	Undercarriage length	STD 2 700 mm (8'10")	LC 2 855 mm (9'4")
*C	Counterweight clearance	760 mm (2'6")	
D	Rear-end swing radius	1 750 mm (5'9")	
D'	Rear-end; length	1 750 mm (5'9")	
E	Overall width of upperstructure	2 205 mm (7'3")	
F	Overall height of cab	2 570 mm (8'5")	
*G	Min. ground clearance	360 mm (1'2")	
H	Track gauge	STD 1 700 mm (5'7")	LC 1 850 mm (6'1")
I	Overall width	STD 2 280 mm (7'6") LC 2 355 mm (7'9")	
J	Overall length	6 160 mm (20'3")	
	With 1.62 m (5'4") arm		
K	Overall height of boom	2 760 mm (9'1")	
	With 1.62 m (5'4") arm		
L	Track shoe width	G: 450 mm (18")	G: 600 mm (24")
		STD 2 150 mm (7'1")	2 300 mm (7'7")
M	Undercarriage width	LC 2 300 mm (7'7")	2 450 mm (8'0")
N	Track height	670 mm (2'2") with triple grouser shoe	

\*Excluding track shoe lug. G: Triple grouser shoe

## WORKING RANGES

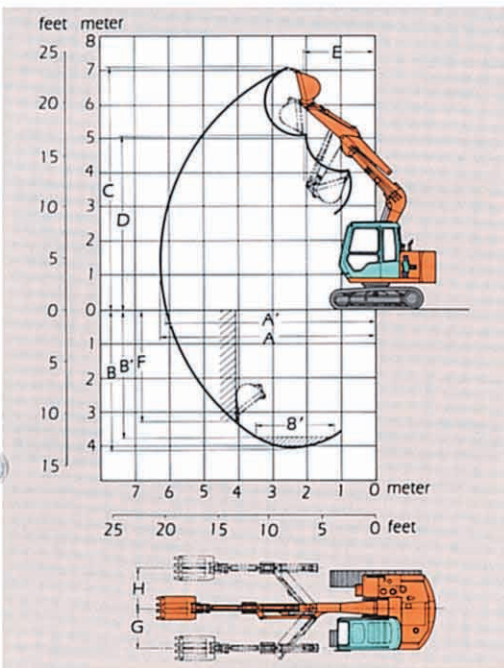

		EX60-3/EX60LC-3 with Off-set front	
		1.62 m (5'4")	
Arm length			
Off-set distance		0 m	Max.
A	Max. digging reach	6 310 mm (20'8")	5 870 mm (19'3")
A'	Max. digging reach (on ground)	6 160 mm (20'3")	5 700 mm (18'8")
B	Max. digging depth	4 150 mm (13'7")	3 700 mm (12'2")
B'	Max. digging depth (8' level)	3 700 mm (12'2")	3 310 mm (10'10")
C	Max. cutting height	7 120 mm (23'4")	6 770 mm (22'3")
D	Max. dumping height	5 070 mm (16'8")	4 720 mm (15'6")
E	Min. swing radius	2 080 mm (6'10")	*2 120 mm/2 190 mm (6'11")/(7'2")
F	Max. vertical wall	3 300 mm (10'10")	2 870 mm (9'5")
G	Left side off-set distance	—	1 090 mm (3'7")
H	Right side off-set distance	—	1 210 mm (4'0")
Bucket digging force		47.1 kN (4 800 kgf, 10 600 lbf)	
Arm crowd force		36.3 kN (3 700 kgf, 8 200 lbf)	

\* Left/Right side off-set.  
700 kg (1 540 lb) counterweight is required.

## EX60-3/EX60LC-3 with Dozer blade

Equipped with 3.72 m (12'2") boom, 1.62 m (5'4") arm, 450 mm (18") triple grouser shoe and 0.28 m<sup>3</sup> (0.37 cy<sup>3</sup>; PCSA heaped) for EX60-3, 0.34 m<sup>3</sup> (0.44 yd<sup>3</sup>; PCSA heaped) for EX60LC-3 bucket.  
Operating weight ..... STD: 6 810 kg (15 000 lb)  
LC : 6 950 kg (15 300 lb)  
Ground pressure ..... STD: 32.4 kPa (0.33 kgf/cm<sup>2</sup>, 4.69 psi)  
LC : 31.4 kPa (0.32 kgf/cm<sup>2</sup>, 4.55 psi)

A	Overall width of blade	2 300 mm (7'7")
B	Overall height of blade	460 mm (1'6")
C	Blade distance	2 000 mm (6'7")
D	Max. raising height above ground	420 mm (1'5")
E	Max. lowering depth from ground	260 mm (10.2")
F	Overall width	2 355 mm (7'9")

## Dimensions

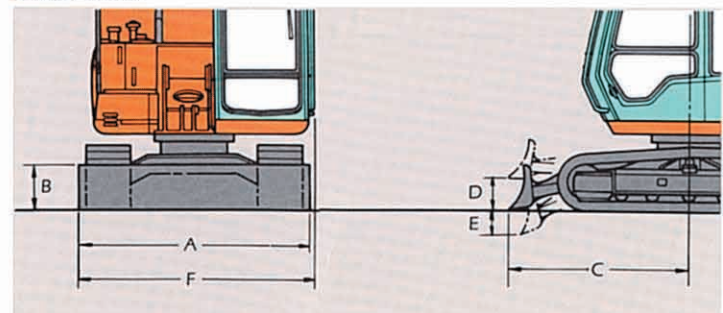



# LIFTING CAPACITIES

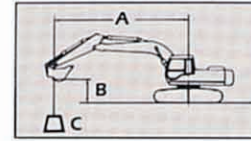

A: Load radius  
B: Load point height  
C: Lifting capacity

## EX60-3



Rating over-side or 360 degrees



Rating over-front

Unit: 1 000 kg (1 000 lb)

Conditions	Load point height m (ft in)	Load radius m (ft in)										At max. reach		
		2 (6'7")		3 (9'10")		4 (13'1")		5 (16'5")		6 (19'8")		@ m (ft in)	m (ft in)	m (ft in)
Boom 3.72 m (12'2") Arm 1.62 m (5'4") Bucket PCSA: 0.28 m <sup>3</sup> (0.37 yd <sup>3</sup> ) CECE: 0.25 m <sup>3</sup> Shoes 450 mm (18")	4 (13'1")			*1.31 (2.89)	*1.31 (2.89)	*1.38 (3.04)	*1.38 (3.04)					0.80 (1.76)	*0.87 (1.92)	5.53 (18'2")
	3 (9'10")			*1.79 (3.95)	*1.79 (3.95)	1.39 (3.06)	*1.58 (3.48)	0.94 (2.07)	1.15 (2.54)			0.70 (1.54)	0.86 (1.90)	5.89 (19'4")
	2 (6'7")			2.08 (4.59)	*2.56 (5.64)	1.32 (2.91)	1.62 (3.57)	0.91 (2.01)	1.12 (2.47)			0.65 (1.43)	0.81 (1.79)	6.03 (19'9")
	1 (3'3")			1.92 (4.23)	2.41 (5.31)	1.25 (2.76)	1.54 (3.40)	0.88 (1.94)	1.08 (2.38)			0.64 (1.41)	0.80 (1.76)	5.98 (19'7")
	0 (Ground)			1.86 (4.10)	2.35 (5.18)	1.20 (2.65)	1.49 (3.29)	0.85 (1.87)	1.05 (2.32)			0.68 (1.50)	0.85 (1.87)	5.72 (18'9")
	-1 (-3'3")	*3.22 (7.10)	*3.22 (7.10)	1.85 (4.08)	2.33 (5.14)	1.18 (2.60)	1.47 (3.24)	0.84 (1.85)	1.04 (2.29)			0.79 (1.74)	0.98 (2.16)	5.23 (17'2")
	-2 (-6'7")	3.86 (8.51)	*4.19 (9.24)	1.87 (4.12)	2.35 (5.18)	1.19 (2.62)	1.48 (3.26)					1.05 (2.32)	1.30 (2.87)	4.41 (14'6")
Boom 3.72 m (12'2") Arm 1.62 m (5'4") Bucket PCSA: 0.28 m <sup>3</sup> (0.37 yd <sup>3</sup> ) CECE: 0.25 m <sup>3</sup> Shoes 450 mm (18")	4 (13'1")					*1.12 (2.47)	*1.12 (2.47)	0.99 (2.18)	1.20 (2.65)			0.69 (1.52)	*0.79 (1.74)	6.07 (19'11")
	3 (9'10")			*1.39 (3.06)	*1.39 (3.06)	*1.34 (2.95)	*1.34 (2.95)	0.97 (2.14)	1.18 (2.60)			0.61 (1.35)	0.75 (1.65)	6.39 (21'0")
	2 (6'7")			*2.14 (4.72)	*2.14 (4.72)	1.36 (3.00)	1.66 (3.66)	0.93 (2.05)	1.14 (2.51)	0.66 (1.46)	0.82 (1.81)	0.57 (1.26)	0.71 (1.57)	6.52 (21'5")
	1 (3'3")			1.98 (4.37)	2.47 (5.45)	1.27 (2.80)	1.57 (3.46)	0.89 (1.96)	1.10 (2.43)	0.65 (1.43)	0.80 (1.76)	0.56 (1.23)	0.71 (1.57)	6.47 (21'3")
	0 (Ground)			1.88 (4.15)	2.36 (5.20)	1.21 (2.67)	1.50 (3.31)	0.85 (1.87)	1.06 (2.34)	0.63 (1.39)	0.79 (1.74)	0.59 (1.30)	0.74 (1.63)	6.24 (20'6")
	-1 (-3'3")	*3.06 (6.75)	*3.06 (6.75)	1.84 (4.06)	2.32 (5.12)	1.17 (2.58)	1.46 (3.22)	0.83 (1.83)	1.04 (2.29)			0.66 (1.46)	0.83 (1.83)	5.80 (19'0")
	-2 (-6'7")	3.78 (8.33)	*4.70 (10.4)	1.84 (4.06)	2.32 (5.12)	1.17 (2.58)	1.46 (3.22)	0.83 (1.83)	1.04 (2.29)			0.83 (1.83)	1.03 (2.27)	5.09 (16'8")
	-3 (-9'10")	3.86 (8.51)	*3.95 (8.71)	1.87 (4.12)	2.36 (5.20)	1.19 (2.62)	1.48 (3.26)							

## EX60LC-3

Conditions	Load point height m (ft in)	Load radius m (ft in)										At max. reach		
		2 (6'7")		3 (9'10")		4 (13'1")		5 (16'5")		6 (19'8")		@ m (ft in)	m (ft in)	m (ft in)
Boom 3.72 m (12'2") Arm 1.62 m (5'4") Bucket PCSA: 0.34 m <sup>3</sup> (0.44 yd <sup>3</sup> ) CECE: 0.30 m <sup>3</sup> Shoes 450 mm (18")	4 (13'1")			*1.29 (2.84)	*1.29 (2.84)	*1.36 (3.00)	*1.36 (3.00)					*0.85 (1.87)	*0.85 (1.87)	5.53 (18'2")
	3 (9'10")			*1.77 (3.90)	*1.77 (3.90)	1.49 (3.29)	*1.56 (3.44)	1.01 (2.23)	1.28 (2.82)			0.74 (1.63)	*0.85 (1.87)	5.89 (19'4")
	2 (6'7")			2.24 (4.94)	*2.55 (5.62)	1.42 (3.13)	1.81 (3.99)	0.98 (2.16)	1.25 (2.76)			0.69 (1.52)	*0.88 (1.94)	6.03 (19'9")
	1 (3'3")			2.08 (4.59)	2.75 (6.06)	1.34 (2.95)	1.73 (3.81)	0.94 (2.07)	1.21 (2.67)			0.69 (1.52)	0.89 (1.96)	5.98 (19'7")
	0 (Ground)			2.02 (4.45)	2.68 (5.91)	1.29 (2.84)	1.68 (3.70)	0.91 (2.01)	1.18 (2.60)			0.73 (1.61)	0.95 (2.09)	5.72 (18'9")
	-1 (-3'3")	*3.23 (7.12)	*3.23 (7.12)	2.01 (4.43)	2.66 (5.87)	1.27 (2.80)	1.65 (3.64)	0.90 (1.98)	1.17 (2.58)			0.84 (1.85)	1.09 (2.40)	5.23 (17'2")
	-2 (-6'7")	*4.17 (9.19)	*4.17 (9.19)	2.03 (4.48)	2.68 (5.91)	1.28 (2.82)	1.66 (3.66)					1.13 (2.49)	1.45 (3.20)	4.41 (14'6")
Boom 3.72 m (12'2") Arm 2.12 m (6'11") Bucket PCSA: 0.28 m <sup>3</sup> (0.37 yd <sup>3</sup> ) CECE: 0.25 m <sup>3</sup> Shoes 450 mm (18")	4 (13'1")					*1.10 (2.43)	*1.10 (2.43)	1.05 (2.32)	*1.23 (2.71)			0.73 (1.61)	*0.77 (1.70)	6.07 (19'11")
	3 (9'10")			*1.37 (3.02)	*1.37 (3.02)	*1.32 (2.91)	*1.32 (2.91)	1.03 (2.27)	1.30 (2.87)			0.65 (1.43)	*0.77 (1.70)	6.39 (21'0")
	2 (6'7")			*2.12 (4.67)	*2.12 (4.67)	1.45 (3.20)	*1.67 (3.68)	1.00 (2.21)	1.27 (2.80)			0.61 (1.35)	0.79 (1.74)	6.52 (21'5")
	1 (3'3")			2.15 (4.74)	2.81 (6.20)	1.37 (3.02)	1.76 (3.88)	0.95 (2.09)	1.22 (2.69)	0.71 (1.57)	0.92 (2.03)	0.60 (1.32)	0.79 (1.74)	6.47 (21'3")
	0 (Ground)			2.04 (4.50)	2.70 (5.95)	1.30 (2.87)	1.69 (3.73)	0.92 (2.03)	1.19 (2.62)	0.69 (1.52)	0.90 (1.98)	0.63 (1.39)	0.83 (1.83)	6.24 (20'6")
	-1 (-3'3")	*3.03 (6.68)	*3.03 (6.68)	2.00 (4.41)	2.65 (5.84)	1.27 (2.80)	1.65 (3.64)	0.89 (1.96)	1.16 (2.56)	0.67 (1.48)	0.88 (1.94)	0.71 (1.57)	0.93 (2.05)	5.80 (19'0")
	-2 (-6'7")	4.19 (9.24)	*4.68 (10.3)	2.00 (4.41)	2.65 (5.84)	1.26 (2.78)	1.64 (3.62)	0.89 (1.96)	1.16 (2.56)			0.89 (1.96)	1.15 (2.54)	5.09 (16'8")
	-3 (-9'10")	*3.93 (8.67)	*3.93 (8.67)	2.04 (4.50)	2.69 (5.93)	1.29 (2.84)	1.67 (3.68)							

Notes: 1. Ratings are based on SAE J1097.

2. Lifting capacity of the Super EX Series does not exceed 75% of tipping load with the machine on firm, level ground or 87% of full hydraulic capacity.

3. The load point is a hook (not standard equipment) loaded on the back of the bucket.

4. \*Indicates load limited by hydraulic capacity.



**EX60-3 with Rubber crawler**



Rating over-side or 360 degrees



Rating over-front

Unit: 1 000 kg (1 000 lb)

Conditions	Load point height m (ft in)	Load radius										At max. reach				
		2 (6'7")		3 (9'10")		4 (13'1")		5 (16'5")		6 (19'8")						
														@	m (ft in)	
Boom 3.72 m (12'2") Arm 1.62 m (5'4") Bucket PCSA: 0.28 m <sup>3</sup> (0.37 yd <sup>3</sup> ) CECE: 0.25 m <sup>3</sup> Shoes R 450 mm (18")	4 (13'1")			*1.31 (2.89)	*1.31 (2.89)	*1.38 (3.04)	*1.38 (3.04)							0.78 (1.72)	*0.87 (1.92)	5.54 (18'2")
	3 (9'10")			*1.80 (3.97)	*1.80 (3.97)	1.36 (3.00)	*1.58 (3.48)	0.91 (2.01)	1.12 (2.47)					0.67 (1.48)	0.83 (1.83)	5.89 (19'4")
	2 (6'7")			2.02 (4.45)	2.50 (5.51)	1.28 (2.82)	1.57 (3.46)	0.88 (1.94)	1.09 (2.40)					0.63 (1.39)	0.78 (1.72)	6.03 (19'9")
	1 (3'3")			1.87 (4.12)	2.34 (5.16)	1.21 (2.67)	1.50 (3.31)	0.85 (1.87)	1.05 (2.32)					0.62 (1.37)	0.78 (1.72)	5.97 (19'7")
	0 (Ground)			1.81 (3.99)	2.28 (5.03)	1.16 (2.56)	1.45 (3.20)	0.82 (1.81)	1.02 (2.25)					0.66 (1.46)	0.82 (1.81)	5.72 (18'9")
	-1 (-3'3")	*3.31 (7.30)	*3.31 (7.30)	1.79 (3.95)	2.27 (5.01)	1.14 (2.51)	1.42 (3.13)	0.81 (1.79)	1.01 (2.23)					0.76 (1.68)	0.95 (2.09)	5.22 (17'2")
	-2 (-6'7")	3.76 (8.29)	*4.17 (9.19)	1.81 (3.99)	2.29 (5.05)	1.15 (2.54)	1.43 (3.15)							1.03 (2.27)	1.27 (2.80)	4.39 (14'5")
		4 (13'1")					*1.13 (2.49)	*1.13 (2.49)	0.96 (2.12)	1.17 (2.58)					0.67 (1.48)	*0.79 (1.74)
	3 (9'10")			*1.40 (3.09)	*1.40 (3.09)	*1.34 (2.95)	*1.34 (2.95)	0.94 (2.07)	1.15 (2.54)					0.59 (1.30)	0.73 (1.61)	6.39 (21'0")
	2 (6'7")			2.10 (4.63)	*2.16 (4.76)	1.32 (2.91)	1.61 (3.55)	0.90 (1.98)	1.11 (2.45)	0.64 (1.41)	0.80 (1.76)			0.55 (1.21)	0.69 (1.52)	6.52 (21'5")
	1 (3'3")			1.92 (4.23)	2.41 (5.31)	1.24 (2.73)	1.52 (3.35)	0.86 (1.90)	1.06 (2.34)	0.62 (1.37)	0.78 (1.72)			0.54 (1.19)	0.68 (1.50)	6.47 (21'3")
	0 (Ground)			1.82 (4.01)	2.30 (5.07)	1.17 (2.58)	1.46 (3.22)	0.82 (1.81)	1.03 (2.27)	0.61 (1.35)	0.76 (1.68)			0.57 (1.26)	0.72 (1.59)	6.23 (20'5")
	-1 (-3'3")	*3.09 (6.81)	*3.09 (6.81)	1.78 (3.92)	2.25 (4.96)	1.14 (2.51)	1.42 (3.13)	0.80 (1.76)	1.00 (2.21)					0.64 (1.41)	0.80 (1.76)	5.79 (19'0")
	-2 (-6'7")	3.68 (8.11)	*4.69 (10.3)	1.78 (3.92)	2.26 (4.98)	1.13 (2.49)	1.41 (3.11)	0.80 (1.76)	1.00 (2.21)					0.80 (1.76)	1.00 (2.21)	5.07 (16'8")
	-3 (-9'10")	3.76 (8.29)	*3.93 (8.67)	1.82 (4.01)	2.29 (5.05)	1.16 (2.56)	1.44 (3.18)									

**EX60LC-3 with Rubber crawler**

Conditions	Load point height m (ft in)	Load radius										At max. reach				
		2 (6'7")		3 (9'10")		4 (13'1")		5 (16'5")		6 (19'8")						
														@	m (ft in)	
Boom 3.72 m (12'2") Arm 1.62 m (5'4") Bucket PCSA: 0.34 m <sup>3</sup> (0.44 yd <sup>3</sup> ) CECE: 0.30 m <sup>3</sup> Shoes R 450 mm (18")	4 (13'1")			*1.29 (2.84)	*1.29 (2.84)	*1.36 (3.00)	*1.36 (3.00)							0.83 (1.83)	*0.85 (1.87)	5.54 (18'2")
	3 (9'10")			*1.79 (3.95)	*1.79 (3.95)	1.45 (3.20)	*1.56 (3.44)	0.98 (2.16)	1.24 (2.73)					0.72 (1.59)	*0.85 (1.87)	5.89 (19'4")
	2 (6'7")			2.18 (4.81)	*2.56 (5.64)	1.38 (3.04)	1.76 (3.88)	0.95 (2.09)	1.21 (2.67)					0.67 (1.48)	0.87 (1.92)	6.03 (19'9")
	1 (3'3")			2.03 (4.48)	2.68 (5.91)	1.31 (2.89)	1.68 (3.70)	0.91 (2.01)	1.17 (2.58)					0.67 (1.48)	0.87 (1.92)	5.97 (19'7")
	0 (Ground)			1.97 (4.34)	2.61 (5.76)	1.25 (2.76)	1.63 (3.59)	0.88 (1.94)	1.14 (2.51)					0.71 (1.57)	0.92 (2.03)	5.72 (18'9")
	-1 (-3'3")	*3.31 (7.30)	*3.31 (7.30)	1.95 (4.30)	2.59 (5.71)	1.23 (2.71)	1.61 (3.55)	0.87 (1.92)	1.13 (2.49)					0.82 (1.81)	1.07 (2.36)	5.22 (17'2")
	-2 (-6'7")	*4.16 (9.17)	*4.16 (9.17)	1.97 (4.34)	2.61 (5.76)	1.24 (2.73)	1.62 (3.57)							1.10 (2.43)	1.43 (3.15)	4.39 (14'5")
		4 (13'1")					*1.11 (2.45)	*1.11 (2.45)	1.03 (2.27)	*1.23 (2.71)					0.71 (1.57)	*0.77 (1.70)
	3 (9'10")			*1.38 (3.04)	*1.38 (3.04)	*1.33 (2.93)	*1.33 (2.93)	1.01 (2.23)	1.28 (2.82)					0.63 (1.39)	*0.77 (1.70)	6.39 (21'0")
	2 (6'7")			*2.14 (4.72)	*2.14 (4.72)	1.41 (3.11)	*1.68 (3.70)	0.97 (2.14)	1.24 (2.73)					0.59 (1.30)	0.77 (1.70)	6.52 (21'5")
	1 (3'3")			2.09 (4.61)	2.74 (6.04)	1.33 (2.93)	1.71 (3.77)	0.93 (2.05)	1.19 (2.62)	0.69 (1.52)	0.89 (1.96)			0.58 (1.28)	0.76 (1.68)	6.47 (21'3")
	0 (Ground)			1.98 (4.37)	2.63 (5.80)	1.27 (2.80)	1.64 (3.62)	0.89 (1.96)	1.15 (2.54)	0.67 (1.48)	0.87 (1.92)			0.61 (1.35)	0.80 (1.76)	6.23 (20'5")
	-1 (-3'3")	*3.07 (6.77)	*3.07 (6.77)	1.94 (4.28)	2.58 (5.69)	1.23 (2.71)	1.61 (3.55)	0.87 (1.92)	1.13 (2.49)	0.65 (1.43)	0.85 (1.87)			0.69 (1.52)	0.90 (1.98)	5.79 (19'0")
	-2 (-6'7")	4.08 (9.00)	*4.67 (10.3)	1.94 (4.28)	2.58 (5.69)	1.22 (2.69)	1.60 (3.53)	0.87 (1.92)	1.13 (2.49)					0.86 (1.90)	1.12 (2.47)	5.07 (16'8")
	-3 (-9'10")	*3.91 (8.62)	*3.91 (8.62)	1.98 (4.37)	2.63 (5.80)	1.25 (2.76)	1.63 (3.59)									

- Notes: 1. Ratings are based on SAE J1097.  
 2. Lifting capacity of the Super EX Series does not exceed 75% of tipping load with the machine on firm level ground or 87% of full hydraulic capacity.  
 3. The load point is a hook [not standard equipment] loaded on the back of the bucket.  
 4. \*Indicates load limited by hydraulic capacity.

**EX60-3 Off-set front with Dozer blade (on ground)**

Rating over-side or 360 degrees



Rating over-front

Unit: 1 000 kg (1 000 lb)

Conditions	Load point height m (ft in)	Load radius m (ft in)										At max. reach		
		2 (6'7")		3 (9'10")		4 (13'1")		5 (16'5")		6 (19'8")		@ m (ft in)		
Boom 3.72 m (12'2") Arm 1.62 m (5'4") Bucket PCSA: 0.28 m <sup>3</sup> (0.37 yd <sup>3</sup> ) CECE: 0.25 m <sup>3</sup> Shoes 450 mm (18") Blade position: front side	4 (13'1")			*1.35 (2.98)	*1.35 (2.98)	*1.32 (2.91)	*1.32 (2.91)					0.81 (1.79)	0.94 (2.07)	5.54 (18'2")
	3 (9'10")			*1.77 (3.90)	*1.77 (3.90)	1.47 (3.24)	*1.50 (3.31)	0.96 (2.12)	1.11 (2.45)			0.68 (1.50)	0.80 (1.76)	5.89 (19'4")
	2 (6'7")					1.34 (2.95)	1.57 (3.46)	0.91 (2.01)	1.06 (2.34)			0.61 (1.35)	0.73 (1.61)	6.03 (19'9")
	1 (3'3")					1.21 (2.67)	1.43 (3.15)	0.84 (1.85)	0.99 (2.18)			0.59 (1.30)	0.71 (1.57)	5.98 (19'7")
	0 (Ground)			1.67 (3.68)	2.01 (4.43)	1.13 (2.49)	1.34 (2.95)	0.79 (1.74)	0.94 (2.07)			0.62 (1.37)	0.74 (1.63)	5.73 (18'10")
	-1 (-3'3")			1.71 (3.77)	2.07 (4.56)	1.09 (2.40)	1.30 (2.87)	0.77 (1.70)	0.91 (2.01)			0.72 (1.59)	0.86 (1.90)	5.24 (17'2")
	-2 (-6'7")	*3.57 (7.87)	*3.57 (7.87)	1.74 (3.84)	2.11 (4.65)	1.10 (2.43)	1.31 (2.89)					0.98 (2.16)	1.16 (2.56)	4.41 (14'6")

**EX60LC-3 Off-set front with Dozer blade (on ground)**

Boom 3.72 m (12'2") Arm 1.62 m (5'4") Bucket PCSA: 0.28 m <sup>3</sup> (0.37 yd <sup>3</sup> ) CECE: 0.25 m <sup>3</sup> Shoes 450 mm (18") Blade position: front side	4 (13'1")			*1.35 (2.98)	*1.35 (2.98)	*1.32 (2.91)	*1.32 (2.91)					0.93 (2.05)	*1.05 (2.32)	5.54 (18'2")
	3 (9'10")			*1.77 (3.90)	*1.77 (3.90)	*1.50 (3.31)	*1.50 (3.31)	1.09 (2.40)	1.25 (2.76)			0.78 (1.72)	0.90 (1.98)	5.89 (19'4")
	2 (6'7")					1.52 (3.35)	1.76 (3.88)	1.03 (2.27)	1.19 (2.62)			0.71 (1.57)	0.83 (1.83)	6.03 (19'9")
	1 (3'3")					1.39 (3.06)	1.62 (3.57)	0.97 (2.14)	1.12 (2.47)			0.70 (1.54)	0.81 (1.79)	5.98 (19'7")
	0 (Ground)			1.93 (4.26)	2.31 (5.09)	1.30 (2.87)	1.53 (3.37)	0.92 (2.03)	1.07 (2.36)			0.73 (1.61)	0.85 (1.87)	5.73 (18'10")
	-1 (-3'3")			1.98 (4.37)	2.39 (5.27)	1.26 (2.78)	1.49 (3.29)	0.90 (1.98)	1.05 (2.32)			0.84 (1.85)	0.98 (2.16)	5.24 (17'2")
	-2 (-6'7")	*3.57 (7.87)	*3.57 (7.87)	2.01 (4.43)	2.43 (5.36)	1.27 (2.80)	1.50 (3.31)					1.14 (2.51)	1.33 (2.93)	4.41 (14'6")

Notes: 1. Ratings are based on SAE J1097.

2. Lifting capacity of the Super EX Series does not exceed 75% of tipping load with the machine on firm, level ground or 87% of full hydraulic capacity.

3. The load point is a hook (not standard equipment) loaded on the back of the bucket.

4. \*Indicates load limited by hydraulic capacity.



## ENGINE

- 25 A alternator
- Dry-type air filter with evacuator valve
- Cartridge-type engine oil filter
- Cartridge type fuel filter
- Radiator and oil cooler with dust protective net
- Radiator reserve tank
- Fan guard
- Isolation-mounted engine
- Auto-idling system

## HYDRAULIC SYSTEM

- ETS
- E-P control system (power mode selector: with speed sensing system)
- OHS
- Hydraulic warm-up control system for hydraulic oil
- Quick warm-up system for pilot circuit
- Shockless valve in pilot circuit
- Swing cushion valve in swing circuit

- Travel cushion valve in travel circuit.
- Accumulator in pilot circuit
- Control valve with main relief valve
- Extra port for control valve
- Suction filter
- Full-flow filter
- Pilot filter

## CAB

All-weather sound-suppressed steel cab equipped with reinforced, tinted (bronze color) glass windows, openable front windows-upper, lower and both side windows with intermittent windshield wipers, curved rear window, adjustable reclining seat with armrests, footrest, electric double horn, auto-tuning radio with digital clock, auto-idle switch, seat belt, cigarette lighter, ashtray, parcel pocket, rear tray, floor mat, heater and pilot control shut-off lever.

## MONITOR SYSTEM

- Meters: Hourmeter, engine coolant temperature gauge and fuel meter.
- Warning lamps: Alternator charge, engine oil pressure, engine overheat, air cleaner clog
- Pilot lamps: Engine preheat.
- Alarm buzzers: Engine oil pressure and engine overheat.

## LIGHTS

- 2 working lights and 1 cab light

## UPPERSTRUCTURE

- Undercover
- 650 kg (1 430 lb) counterweight
- Fuel level gauge
- Hydraulic oil level gauge
- Tool box
- Swing parking brake

## UNDERCARRIAGE

- Travel parking brake
- Travel motor covers
- Hydraulic track adjuster
- Bolt-on sprocket
- Upper rollers and lower rollers
- Reinforced track links with pin seals
- 450 mm (18") triple grouser shoes

## FRONT ATTACHMENTS

- Bucket clearance adjust mechanism
- Monolithically cast bucket link A
- Centralized lubrication system
- Dirt seals on all bucket pins
- 1.62 m (5'4") arm
- 0.28 m<sup>3</sup> (0.37 yd<sup>3</sup>: PCSA heaped) bucket

## MISCELLANEOUS

- Standard tool kit
- Lockable machine covers
- Fuel filling cap
- Skid-resistant tapes and handrails.

- Air conditioner
- Multi selection lever with rotary valve
- Electric fuel refilling pump
- Swing alarm with lamps
- Travel alarm with cancel switch

### Type of Bucket

### Type of Shoe

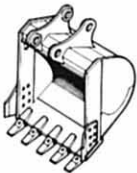

Reinforced bucket

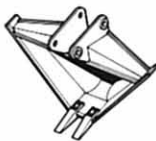

V-shaped bucket



Slope-finishing blade

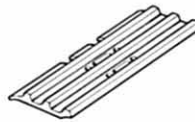

Triple grouser shoe  
600 mm (24")

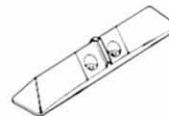

Triangular shoe  
500 mm (20"),  
700 mm (28")



Flat shoe  
450 mm (18")