

HITACHI

# SuperEX **V** EX100

Rated Engine HP: 59 kW (80 PS)

Operating Weights

EX100-5: 10 700 kg (23 600 lb)

EX100M-5: 12 400 kg (27 300 lb)

Bucket Capacity

PCSA Heaped: 0.19 — 0.59 m<sup>3</sup> (0.25 — 0.77 yd<sup>3</sup>)

CECE Heaped: 0.17 — 0.50 m<sup>3</sup>





# The Quest for Real Value: The Super EX-V

Technological advances are limitless. The Quest for Real Value — That's Hitachi's new challenge. The result is the Super EX-V, featuring responsiveness of human-touch control, agile movements, operator-first cab, and an environmentally-friendly design. The Super EX-V is the productive, powerful hydraulic excavator, which reduces lifetime costs. The advent of the Hitachi hydraulic excavator with real value. . . just the beginning of Hitachi's next giant stride.

## Super EX-V EX100



# Quick-Responding Control Enhances Easy, Productive Operation.

### 1 The Advanced Hydraulic System — a Hitachi original — the Heart of the Super EX-V.

Here's versatility . . . a phase of real value. The advanced hydraulic system provides impressive versatility, allowing a variety of operations, such as digging, grading, finishing, and materials handling, with power and speed.

This hydraulic system provides:

- Smooth operations.
- Matched combined operations.
- Reduces operator fatigue.

In other words, the Super EX-V delivers superior combined operations, quick level finishing, nimble slope tamping, and simple positioning for demolition, as well as straight-line travel and accurate steering

### 2 HP Mode for More Productivity

When power is needed, select the HP mode. This automatically boosts engine output to 60 kW (82 PS) from 59 kW (80 PS) for increased productivity in heavy-duty operations. In light-duty, such as swing or dumping, engine output is reduced automatically to 59 kW (80 PS) for fuel savings.

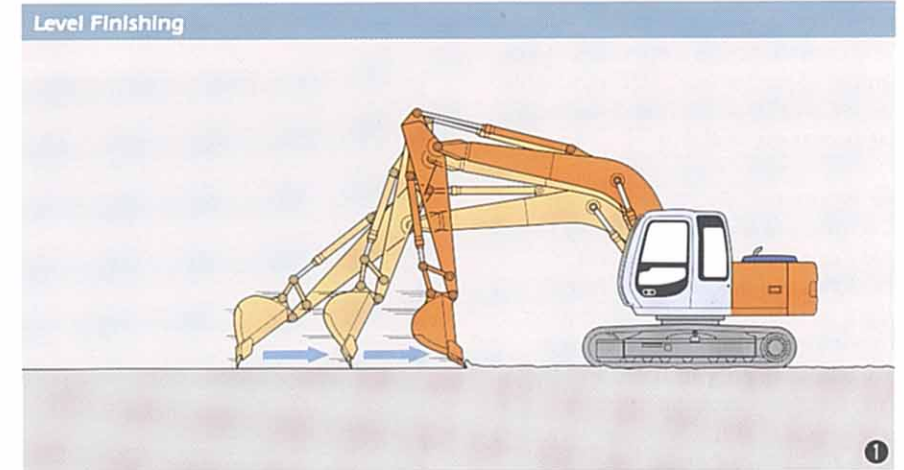

• Increased finishing speed

### Slope Finishing

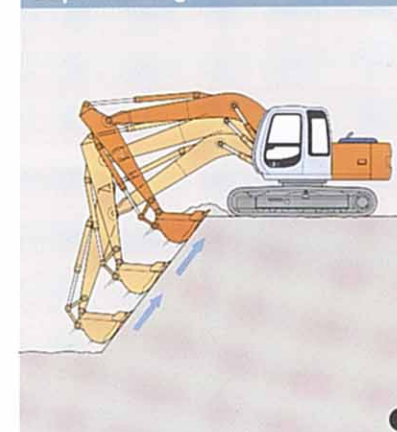

• Smooth front control

### 2 E Mode for Reduced Fuel Consumption

In light-duty operation, when the E mode is selected, engine speed is reduced for fuel savings. This enhances fuel-efficient operation.

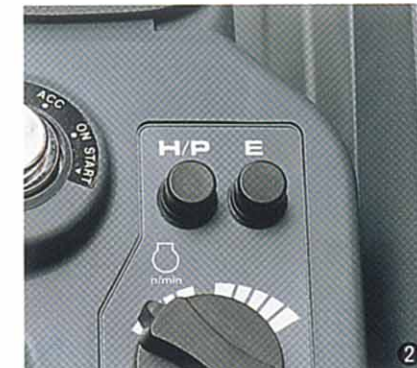

### 3 Four Work Modes for Increased Productivity

- 1 General Purpose Mode: For efficient excavation.
- 2 Grading Mode: The arm rolls in slowly and powerfully and rolls out quickly for efficient grading.
- 3 Precision Mode: For precision finishing.
- 4 Attachment Mode: Oil flow is adjusted to the special attachment in use, such as a hydraulic breaker.

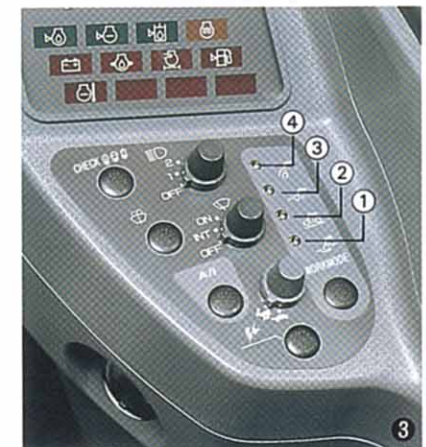



# Operator Comfort Creates Higher Productivity.

## ● Roomy Cab with Superior Visibility

The operator's cab is spacious, with ample space for legs. The retractable wiper and large overhead window help increase visibility.

## ① Ergonomically Arranged Controls

Controls are arranged logically for easy operation. Monitors and switches are placed at the front right position, and engine controls to the right of the operator's seat. Switches are easy to read, and the fuel throttle is dial type.

## ② 6 Fluid-Filled Elastic Mounts

Cab shocks and vibration are dampened with 6 fluid-filled elastic mounts in place of a conventional 4-point mount. This reduces operator's fatigue.

## ● Glove Compartment and Hot-and-Cool Box

A glove compartment (standard) is provided behind the operator's seat for operator convenience. A hot-and-cool box (option) is available.

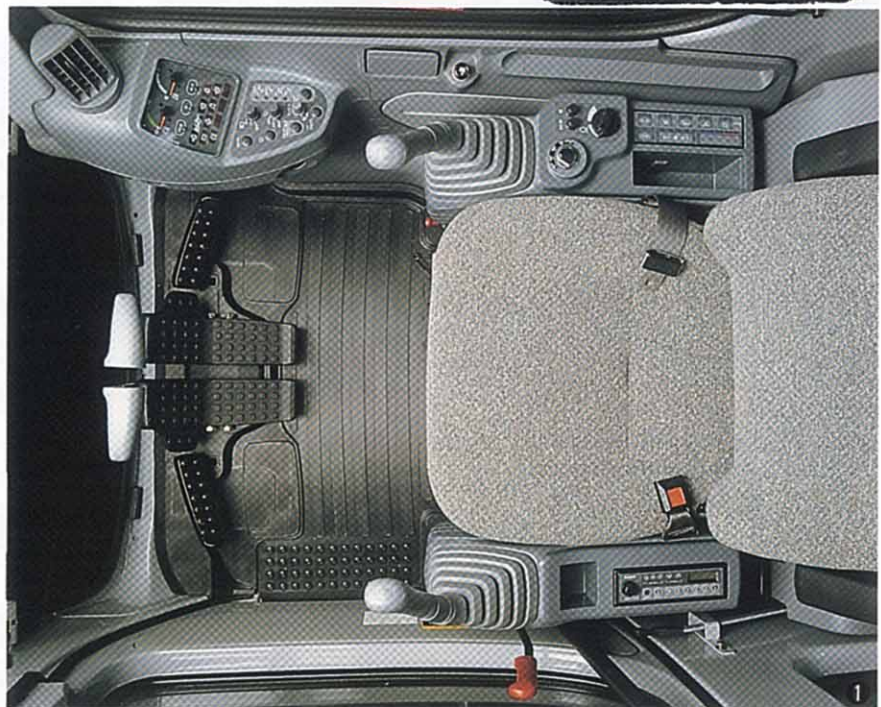
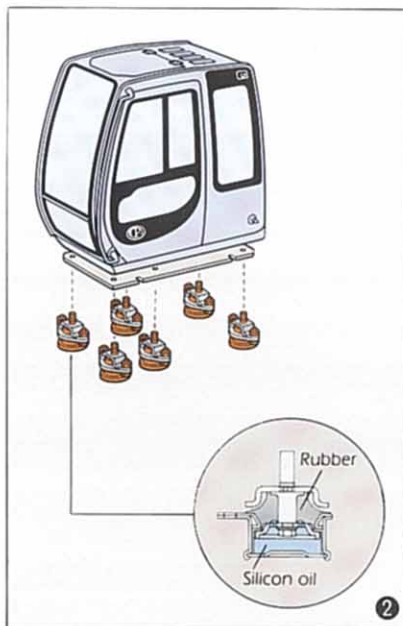

Show in this photo is fitted with optional equipment.



## ④ Tilt-type Seat Cushion and Three-stage Adjustable Controls

The front part and the rear part of the seat cushion can be adjusted up and down independently to help the operator find the most comfortable operating position. Also, the controls can be adjusted in three stages to fit each operator.

## ③ Fresh Air Type Large-Capacity Air-Conditioner is Optionally Available

Operator comfort is further enhanced with an air-conditioner with ample capacity, 1.5 times that of the previous model, and rotatable blower louvers also serve as defrosters. Thus, rapid air-conditioning can be achieved for operator comfort.

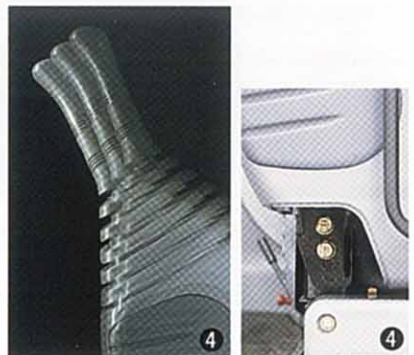

# Operator- and Environmentally-Friendly Design Enhances Simplified Maintenance and Reliability

## ① Low Noise Design

The newly developed low-noise pump and large-sized muffler are employed to eliminate irritating high-pitch noise.

- Noise Level at Operator's ear: 71 dB (A)
- Noise Level at 7 m (23'0") away: 71 dB (A)

## ② Evacuation Tool and Large Overhead Window

An evacuation tool is provided for emergency evacuation. A large overhead window can be used as an emergency exit.

## ③ Easy Maintenance Permitted by HN Bushings

The HN bushings are made of a sintered composite iron alloy with high-viscosity lubricating oil vacuum impregnated in micron-sized pores. They are carburized for reliable and durable.



• Radiator fan guard



• Large handrail

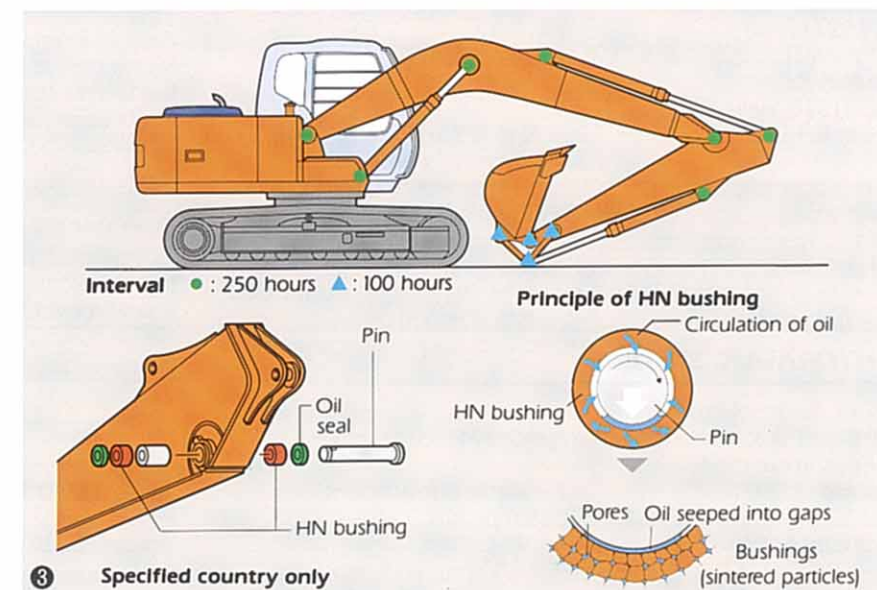

③ Specified country only

## ④ Dependability and Durability

The front attachment, main frame, track frame, and travel motor covers are all reinforced for increased dependability and durability.



• Reinforced boom center boss

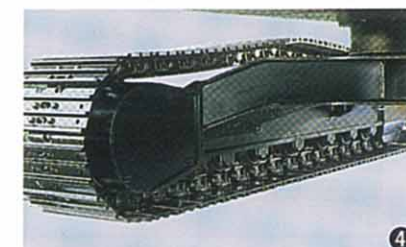

• Round travel motor cover

## ⑤ Auto Lubrication System (Option)

Auto lubrication eases daily maintenance at the boom and arm pins.



▲ Lubricating points



## ENGINE

Model .....	Isuzu A-4BG1
Type .....	4-cycle, water-cooled, direct injection
No. of cylinders .....	4
Rated flywheel .....	59 kW (80 PS) at 2 100 min <sup>-1</sup> (rpm)
horsepower (DIN 6271, net)	
Rated flywheel .....	57 kW (76 HP) at 2 100 min <sup>-1</sup> (rpm)
horsepower (SAE J1349, net)	
Maximum torque .....	284 N·m (29 kgf·m, 210 lbf·ft)
at 1 500 min <sup>-1</sup> (rpm)	
Piston displacement .....	4.329 L (264 in <sup>3</sup> )
Bore and stroke .....	105 mm × 125 mm (4.13" × 4.92")
Batteries .....	2 × 12 V, 65 AH
Governor .....	Mechanical, speed control with stepping motor

## HYDRAULIC SYSTEM

- Work mode selector  
General Purpose mode / Grading mode / Precision mode / Attachment mode

Main pump .....	2 variable displacement axial piston pumps
Maximum oil flow .....	2 × 95 L / min (25.1 US gpm, 20.9 Imp gpm)
Pilot pump .....	1 gear pump
Maximum oil flow .....	35.3 L / min (9.3 US gpm, 7.8 Imp gpm)

## Hydraulic Motors

Travel .....	2 variable displacement axial piston motors
Swing .....	1 axial piston motor

## Relief Valve Settings

Implement circuit .....	34.3 MPa (350 kgf/cm <sup>2</sup> , 4 980 psi)
Swing circuit .....	31.4 MPa (320 kgf/cm <sup>2</sup> , 4 550 psi)
Travel circuit .....	34.3 MPa (350 kgf/cm <sup>2</sup> , 4 980 psi)
Pilot circuit .....	3.7 MPa (38 kgf/cm <sup>2</sup> , 540 psi)

## Hydraulic Cylinders

High-strength piston rods and tubes. Cylinder cushion mechanisms provided in all cylinders to absorb shock at stroke ends.

## Dimensions

	Qty	Bore	Rod diameter
Boom	2	95 mm (3.74")	70 mm (2.76")
Arm	1	105 mm (4.13")	75 mm (2.95")
Bucket	1	95 mm (3.74")	65 mm (2.56")

## Hydraulic Filters

Hydraulic circuits use high-quality hydraulic filters. A suction filter is incorporated in suction line, and 10 μm full-flow filters in return line and swing/travel motor drain lines.

## CONTROLS

Pilot controls. Hitachi's original shockless valve and quick warm-up system built in the pilot circuit. Hydraulic warm-up control system for engine and hydraulic oil.

Implement levers .....	2
Travel levers with pedals .....	2

## UPPERSTRUCTURE

### Revolving Frame

Welded sturdy box construction, using heavy-gauge steel plates for ruggedness. D-section frame for resistance to deformation.

### Swing Mechanism

Axial piston motor with planetary reduction gear is bathed in oil. Swing circle is single-row, shear-type ball bearing with induction-hardened internal gear. Internal gear and pinion gear are immersed in lubricant. Swing parking brake is spring-set/hydraulic-released disc type.  
Swing speed ..... 13.5 min<sup>-1</sup> (rpm)

### Operator's Cab

Independent roomy cab, 1 005 mm (40") wide by 1 665 mm (66") high, conforming to ISO\* Standards. Reinforced glass windows on 4 sides for visibility. Front windows (upper and lower) are openable. Adjustable, reclining seat with armrests; movable with or without control levers.

\* International Standardization Organization

## UNDERCARRIAGE

### Tracks

Tractor-type undercarriage. Welded track frame using carefully selected materials. Side frame welded to track frame. Lubricated track rollers, idlers, and sprockets with floating seals. Track shoes with triple grousers made of induction-hardened rolled alloy. Flat and triangular shoes also available. Heat-treated connecting pins with dirt seals. Hydraulic (grease) track adjusters with shock-absorbing recoil springs.

### Numbers of Rollers and Shoes on Each Side

Upper roller .....	1: EX100-5 2: EX100M-5
Lower rollers .....	6: EX100-5 6: EX100M-5
Track shoes .....	41: EX100-5 42: EX100M-5

### Traction Device

Each track driven by 2-speed axial piston motor through planetary reduction gear for counterrotation of the tracks. Sprockets are replaceable. Parking brake is spring-set/hydraulic-released disc type. Travel shockless relief valve built in travel motor absorbs shocks when stopping travel.

Automatic transmission system: High—Low.

Travel speeds	
EX100-5 .....	High: 0 to 5.5 km/h (3.4 mph) Low: 0 to 3.5 km/h (2.2 mph)
EX100M-5 .....	High: 0 to 4.4 km/h (2.7 mph) Low: 0 to 2.7 km/h (1.7 mph)

Maximum traction force	
EX100-5 .....	87.3 kN (8 900 kgf, 19 600 lbf)
EX100M-5 .....	118.7 kN (12 100 kgf, 26 700 lbf)
Gradeability .....	35° (70%) continuous

## WEIGHTS AND GROUND PRESSURE

Equipped with 4.27 m (14'0") boom, 2.26 m (7'5") arm and 0.46 m<sup>3</sup> (0.60 yd<sup>3</sup>: PCSA heaped) bucket.

### EX100-5

Shoe type	Shoe width	Standard undercarriage	
		Operating weight	Ground pressure
Triple grouser	500 mm (20")	10 700 kg (23 600 lb)	37 kPa (0.38 kgf/cm <sup>2</sup> , 5.40 psi)
	600 mm (24")	11 000 kg (24 300 lb)	31 kPa (0.32 kgf/cm <sup>2</sup> , 4.55 psi)
	700 mm (28")	11 200 kg (24 700 lb)	27 kPa (0.28 kgf/cm <sup>2</sup> , 3.98 psi)
Rubber	500 mm (20")	10 700 kg (23 600 lb)	36 kPa (0.37 kgf/cm <sup>2</sup> , 5.26 psi)
Flat	510 mm (20")	11 200 kg (24 700 lb)	37 kPa (0.38 kgf/cm <sup>2</sup> , 5.40 psi)
Triangular	700 mm (28")	11 000 kg (24 300 lb)	27 kPa (0.28 kgf/cm <sup>2</sup> , 3.98 psi)

### EX100M-5

Shoe type	Shoe width	Marsh type undercarriage	
		Operating weight	Ground pressure
Triple grouser	700 mm (28")	12 400 kg (27 300 lb)	27 kPa (0.28 kgf/cm <sup>2</sup> , 3.98 psi)
Single high grouser	960 mm (38")	13 400 kg (29 500 lb)	22 kPa (0.22 kgf/cm <sup>2</sup> , 3.13 psi)
Triangular	760 mm (30")	13 100 kg (28 900 lb)	26 kPa (0.27 kgf/cm <sup>2</sup> , 3.84 psi)
	900 mm (35")	13 200 kg (29 100 lb)	23 kPa (0.23 kgf/cm <sup>2</sup> , 3.27 psi)

Weights of the basic machines [including 1 700 kg (3 750 lb), counterweight and triple grouser shoes, excluding front-end attachment, fuel, Hyd. oil, Eng. oil and coolant etc.] are:

EX100-5 .....	8 500 kg (18 700 lb) with 500 mm (20") shoes.
EX100M-5 .....	10 200 kg (22 500 lb) with 700 mm (28") shoes.

## Buckets

Capacity		Width		No. of teeth	Weight	Recommendation					
PCSA heaped	CECE heaped	Without side cutters	With side cutters			EX100-5			EX100M-5		
						1.96 m (6'5") arm	2.26 m (7'5") arm	2.81 m (9'3") arm	1.96 m (6'5") arm	2.26 m (7'5") arm	2.81 m (9'3") arm
0.19 m <sup>3</sup> (0.25 yd <sup>3</sup> )	0.17 m <sup>3</sup>	450 mm (18")	550 mm (22")	3	240 kg (530 lb)	●	●	●	●	●	●
0.30 m <sup>3</sup> (0.39 yd <sup>3</sup> )	0.25 m <sup>3</sup>	580 mm (23")	700 mm (28")	3	280 kg (620 lb)	●	●	●	●	●	●
0.40 m <sup>3</sup> (0.52 yd <sup>3</sup> )	0.33 m <sup>3</sup>	680 mm (27")	800 mm (31")	4	330 kg (730 lb)	●	●	●	●	●	●
0.46 m <sup>3</sup> (0.60 yd <sup>3</sup> )	0.40 m <sup>3</sup>	850 mm (33")	970 mm (38")	5	380 kg (840 lb)	●	●	○*	●	●	●
0.55 m <sup>3</sup> (0.72 yd <sup>3</sup> )	0.45 m <sup>3</sup>	890 mm (35")	1 010 mm (40")	5	400 kg (880 lb)	●	○	—	●	○	○
0.59 m <sup>3</sup> (0.77 yd <sup>3</sup> )	0.50 m <sup>3</sup>	950 mm (37")	1 070 mm (42")	5	410 kg (900 lb)	○	□	—	○	□	—
*1 0.46 m <sup>3</sup> (0.60 yd <sup>3</sup> )	0.40 m <sup>3</sup>	850 mm (33")	970 mm (38")	5	440 kg (970 lb)	●	●	○*	●	●	●
*2 0.55 m <sup>3</sup> (0.72 yd <sup>3</sup> )	0.45 m <sup>3</sup>	890 mm (35")	1 010 mm (40")	5	490 kg (1 080 lb)	○	—	—	○	—	—
*3 0.55 m <sup>3</sup> (0.72 yd <sup>3</sup> )	0.45 m <sup>3</sup>	890 mm (35")	1 010 mm (40")	5	470 kg (1 040 lb)	○	—	—	○	—	—
V-Type bucket: 0.35 m <sup>3</sup> (0.46 yd <sup>3</sup> : CECE heaped)					3	370 kg (820 lb)	●	●	●	●	●
One-point ripper					1	320 kg (710 lb)	●	●	—	—	—
Clamshell bucket: 0.30 m <sup>3</sup> (0.39 yd <sup>3</sup> : CECE heaped), Width 560 mm (22")					6	690 kg (1 520 lb)	●	●	—	●	—
Slope-finishing blade: Width 1 000 mm (39"), Length 1 600 mm (63")						475 kg (1 050 lb)	◇	◇	◇	◇	◇

\* With 700 mm (28") shoes only  
 \*1 Reinforced bucket  
 \*2 Level-pin-reinforced bucket  
 \*3 H-bucket

● Suitable for materials with density of 2 000 kg/m<sup>3</sup> (3 370 lb/yd<sup>3</sup>) or less  
 ○ Suitable for materials with density of 1 600 kg/m<sup>3</sup> (2 700 lb/yd<sup>3</sup>) or less  
 □ Suitable for materials with density of 1 100 kg/m<sup>3</sup> (1 850 lb/yd<sup>3</sup>) or less  
 ● Heavy-duty service  
 ◇ Slope finishing service  
 — Not recommended

## SERVICE REFILL CAPACITIES

	liters	US gal	Imp gal
Fuel tank .....	250.0	66.1	55.0
Engine coolant .....	18.4	4.9	4.0
Engine oil .....	14.7	3.9	3.2
Swing mechanism .....	3.2	0.8	0.7
Travel final drive .....	3.0	0.8	0.7
device (each side) EX100M-5 ...	4.4	1.2	1.0
Hydraulic system .....	134.0	35.4	29.5
Hydraulic tank .....	69.0	18.2	15.2

## BACKHOE ATTACHMENTS

Boom and arms are of welded, box-section design. 4.27 m (14'0") boom, and 1.96 m (6'5"), 2.26 m (7'5") and 2.81 m (9'3") arms are available. Bucket is of welded steel structure. Side clearance adjust mechanism provided on the bucket joint bracket.



## DIMENSIONS

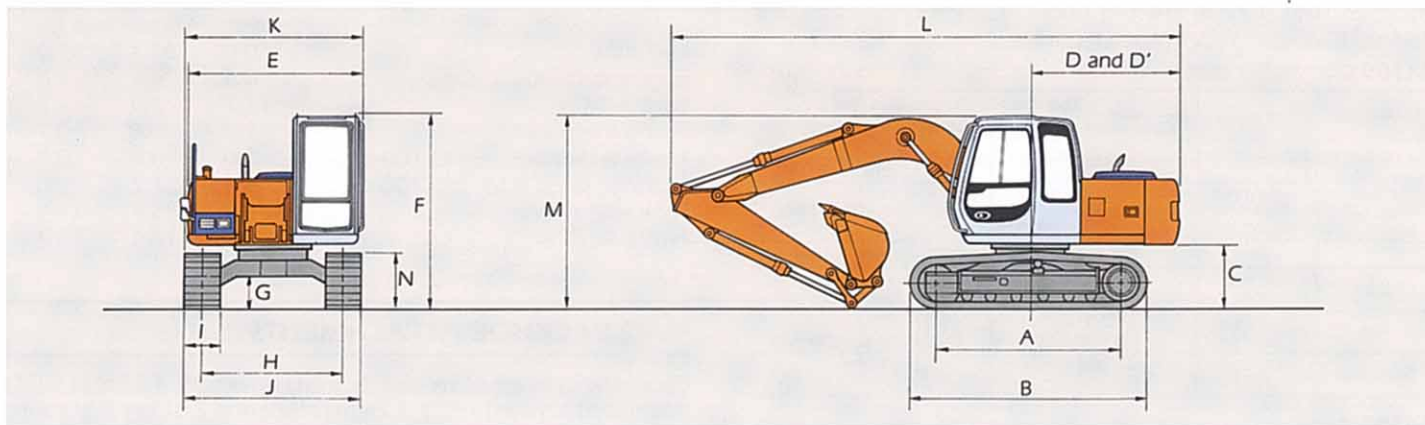

	EX100-s				EX100M-s		
A	Distance between tumblers				2 620 mm [8'7"]		
B	Undercarriage length				3 340 mm [10'11"]		
*C	Counterweight clearance				890 mm [2'11"]		
D	Rear-end swing radius				2 130 mm [7'0"]		
D'	Rear-end length				2 100 mm [6'11"]		
E	Overall width of upperstructure				2 460 mm [8'1"]		
F	Overall height of cab				2 720 mm [8'11"]		
*G	Min. ground clearance				440 mm [1'5"]		
H	Track gauge				1 990 mm [6'6"]		
I	Standard track shoe width				G500 mm [20"]	G600 mm [24"]	G700 mm [28"]
J	Undercarriage width				2 490 mm [8'2"]	2 590 mm [8'6"]	2 690 mm [8'10"]
K	Overall width				2 500 mm [8'2"]	2 590 mm [8'6"]	2 690 mm [8'10"]
L	Overall length				2 500 mm [8'2"]		
	With 1.96 m [6'5"] arm				7 190 mm [23'7"]		
	With 2.26 m [7'5"] arm				7 190 mm [23'7"]		
	With 2.81 m [9'3"] arm				7 210 mm [23'8"]		
M	Overall height of boom				2 600 mm [8'6"]		
	With 1.96 m [6'5"] arm				2 680 mm [8'10"]		
	With 2.26 m [7'5"] arm				2 680 mm [8'10"]		
	With 2.81 m [9'3"] arm				**2 680 mm [8'10"]		
N	Track height				790 mm [2'7"]		
	With triple grouser shoe				930 mm [3'1"]		

\* Excluding track shoe lug.

\*\* This dimension is shown in the transportation hole position of the arm

G: Triple grouser shoe  
T: Triangular shoe

F: Flat shoe  
H: Triple high grouser shoe

## WORKING RANGES

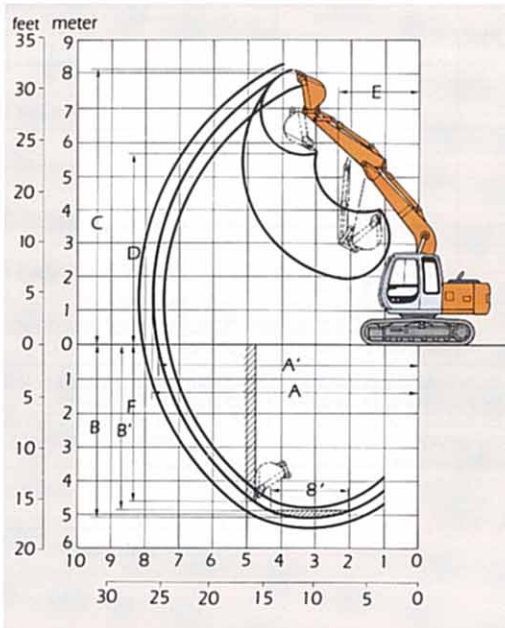

Unit: mm (ft in)

Arm length	EX100-s			EX100M-s		
	1.96 m [6'5"]	2.26 m [7'5"]	2.81 m [9'3"]	1.96 m [6'5"]	2.26 m [7'5"]	2.81 m [9'3"]
A Max. digging reach	7 430 [24'5"]	7 700 [25'3"]	8 180 [26'10"]	7 430 [24'5"]	7 700 [25'3"]	8 180 [26'10"]
A' Max. digging reach (on ground)	7 290 [23'11"]	7 570 [24'10"]	8 050 [26'5"]	7 250 [23'9"]	7 530 [24'8"]	8 010 [26'3"]
B Max. digging depth	4 780 [15'8"]	5 080 [16'8"]	5 630 [18'6"]	4 580 [15'0"]	4 880 [16'0"]	5 430 [17'10"]
B' Max. digging depth (B' level)	4 520 [14'10"]	4 850 [15'11"]	5 430 [17'10"]	4 320 [14'2"]	4 640 [15'3"]	5 220 [17'2"]
C Max. cutting height	7 930 [26'0"]	8 110 [26'7"]	8 360 [27'5"]	8 140 [26'8"]	8 320 [27'4"]	8 570 [28'1"]
D Max. dumping height	5 530 [18'2"]	5 700 [18'8"]	5 960 [19'7"]	5 730 [18'10"]	5 910 [19'5"]	6 170 [20'3"]
E Min. swing radius	2 300 [7'7"]	2 330 [7'8"]	2 590 [8'6"]	2 300 [7'7"]	2 330 [7'8"]	2 590 [8'6"]
F Max. vertical wall	4 320 [14'2"]	4 620 [15'2"]	5 120 [16'10"]	4 120 [13'6"]	4 420 [14'6"]	4 920 [16'2"]
Bucket digging force	89 kN [9 100 kgf, 20 100 lbf]					
	SAE: PCSA 78 kN [8 000 kgf, 17 600 lbf]					
Arm crowd force	60 kN [6 100 kgf, 13 400 lbf]	55 kN [5 600 kgf, 12 300 lbf]	48 kN [4 900 kgf, 10 800 lbf]	60 kN [6 100 kgf, 13 400 lbf]	55 kN [5 600 kgf, 12 300 lbf]	48 kN [4 900 kgf, 10 800 lbf]
	58 kN [5 900 kgf, 13 000 lbf]	53 kN [5 400 kgf, 11 900 lbf]	47 kN [4 800 kgf, 10 600 lbf]	58 kN [5 900 kgf, 13 000 lbf]	53 kN [5 400 kgf, 11 900 lbf]	47 kN [4 800 kgf, 10 600 lbf]

Excluding track shoe lug

## SE STANDARD EQUIPMENT

Standard equipment may vary by country, so please consult your Hitachi dealer for details.

### ENGINE

- HP mode control
- E mode control
- 40 A alternator
- Dry-type air filter with evacuator valve (with safety element)
- Cartridge-type engine oil filter
- Cartridge-type engine oil bypass filter
- Cartridge type fuel filter
- Air cleaner double element
- Radiator and oil cooler with dust protective net
- Radiator reserve tank
- Fan guard
- Isolation-mounted engine
- Auto-idle system

### CAB

All-weather sound-suppressed steel cab equipped with reinforced, tinted (bronze color) glass windows, 6 fluid-filled elastic mounts, openable front windows-upper, and lower and left side windows with intermittent windshield retractable wiper, front window washer, adjustable reclining seat with adjustable armrests, footrest, electric double horn, auto-tuning radio with digital clock, auto-idle switch, seat belt, cigarette lighter, ashtray, parcel pocket, glove compartment, floor mat, heater, and pilot control shut-off lever.

### ALARM BUZZERS:

- Engine oil pressure and engine overheat

### LIGHTS

- 2 working lights

### UPPERSTRUCTURE

- Undercover
- 1 700 kg [3 750 lb] counterweight
- Fuel level float
- Hydraulic oil level gauge
- Tool box
- Rearview mirror (right side)
- Swing parking brake

### FRONT ATTACHMENTS

- HN bushing
- Bucket clearance adjust mechanism
- Monolithically cast bucket link A
- Centralized lubrication system
- Dirt seals on all bucket pins
- 2.26 m [7'5"] arm
- 0.46 m<sup>3</sup> [0.60 yd<sup>3</sup>: PCSA heaped] bucket

### MISCELLANEOUS

- Standard tool kit
- Lockable machine covers
- Lockable fuel filling cap
- Skid-resistant tapes and handrails.

### HYDRAULIC SYSTEM

- Work mode selector
- E-P control system
- Quick warm-up system for pilot circuit
- Shockless valve in pilot circuit
- Boom-arm anti-drift valve
- Control valve with main relief valve
- Extra port for control valve
- Suction filter
- Full-flow filter
- Pilot filter

### MONITOR SYSTEM

- Meters:
  - Hourmeter, engine coolant temperature gauge and fuel meter.
- Warning lamps:
  - Alternator charge, engine oil pressure, engine overheat, air cleaner clog and minimum fuel level.
- Pilot lamps:
  - Engine preheat, engine oil level, engine coolant level and hydraulic oil level.

### UNDERCARRIAGE

- Travel parking brake
- Travel motor covers
- Hydraulic track adjuster
- Bolt-on sprocket
- Upper rollers and lower rollers
- Reinforced track links with pin seals
- 500 mm [20"] triple grouser shoes (EX100-s)
- 700 mm [28"] triple grouser shoes (EX100M-s)

## SE OPTIONAL EQUIPMENT

Optional equipment may vary by country, so please consult your Hitachi dealer for details.

- Air conditioner
- Suspension seat
- AM-FM radio
- Hose rupture valves
- Electric fuel refilling pump
- Swing motion alarm device with lamp
- Travel motion alarm device
- Additional pump
- Piping kit for extra valve port
- Additional valve with piping kit
- PTO valve with piping kit
- Auto-lubrication system
- Pre-cleaner
- Tropical cover

- Front glass lower guard
- Track guard
- 0.55 m<sup>3</sup> [0.72 yd<sup>3</sup>: PCSA heaped] H-bucket: 1.96 m [6'5"] arm only
- 0.55 m<sup>3</sup> [0.72 yd<sup>3</sup>: PCSA heaped] Level pin-reinforced bucket: 1.96 m [6'5"] arm only
- One-point ripper for ripping hardpan
- Clamshell bucket for deep vertical excavations such as manholes, pilings, footings, etc.
- Slope-finishing blade for slope finishing jobs... scraping up or down, compacting, leveling, grading etc.





 **Hitachi Construction Machinery Co., Ltd.**

**Head Office:** Nippon Bldg., 6-2, 2-chome, Ohtemachi,  
Chiyoda-ku, Tokyo 100-0004, Japan

**Telephone:** Tokyo (03) 3245-6390

**Facsimile:** Tokyo (03) 3246-2609

These specifications are subject to change without notice.  
Illustrations and photos show the standard models, and may or may not include optional  
equipment, accessories, and all standard equipment, with some differences in color and  
features.

