

LX80

HITACHI

# LX80

W H E E L L O A D E R

- **Engine Rated Power** : 80.9 kW (110 PS)
- **Operating Weight** : Canopy / (Rops / Fops) Cab  
8 120 kg / 8 610 kg
- **Backhoe Bucket** : ISO Heaped  
1.3 m<sup>3</sup> – 1.9 m<sup>3</sup>

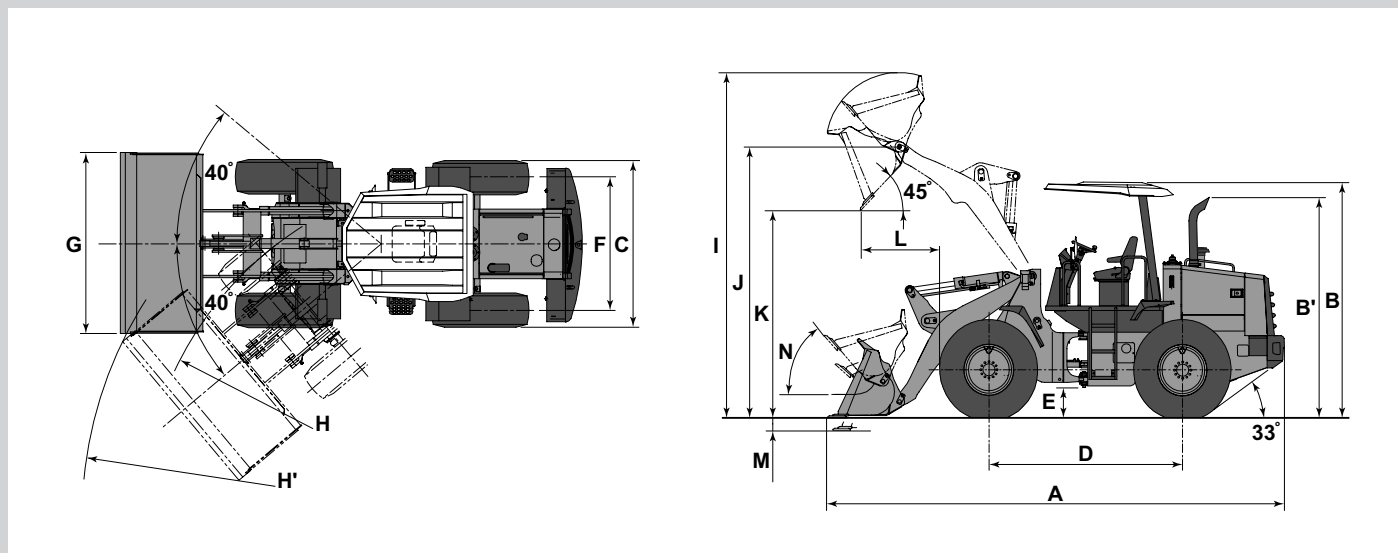

Unit : mm

	LX80-7
A Overall length	6 360
B Height to top of canopy and cab	3 140
B' Height to top of exhaust	2 985
C Width over tires	2 320
D Wheel base	2 600
E Ground clearance	365
F Tread	1 820
G Bucket width	2 480
H Turning radius (Centerline of outside tire)	4 690
H' Loader clearance circle, bucket in carry position	5 470
I Overall operating height	4 675
J Height to bucket hinge pin, fully raised	3 605
K Dumping clearance 45 degree, full height	2 740
L Reach, 45 degree dump, full height	1 030
Reach, 45 degree dump, 7 ft (2.13 m) clearance	1 480
M Digging depth (Horizontal digging angle)	85
N Max. roll back at carry position	48 deg.
Tire size	17.5 - 25 - 12PR (L2)

Note: General purpose bucket with bolt on cutting edges.



## ENGINE

Model .....	Isuzu DD-4BG1T
Type .....	4-cycle water-cooled, direct injection
Aspiration .....	Turbocharger
No. of cylinders .....	4
Rated power	
DIN 6 271, net .....	80.9 kW (110 PS) at 2 200 min <sup>-1</sup> (2 200 rpm)
SAE J1349, net .....	80.9 kW (108 HP) at 2 200 min <sup>-1</sup> (2 200 rpm)
Bore and stroke .....	105 mm x 125 mm
Piston displacement .....	4.329 L
Electrical system .....	24 volt with 0.96 kW, 50 A alternator
Starting system .....	24 V x 4.5 kW electric motor.
Batteries .....	2 x 12 V / 582 CCA, 133-min. rated reserve
Air cleaner .....	Single element dry type with restriction indicator



## POWER TRAIN

Transmission .....	Two-speed shifts ; high/low speed selection through hydraulic clutch
Cooling method .....	Forced circulation type
Travel speed* : km/h	
	Forward / Reverse
Low .....	12.5 / 12.5
High .....	34.5 / 34.5

\* With 17.5-25-12PR (L2) tires



## AXLE AND FINAL DRIVE

Drive system .....	Four-wheel drive system
Front & rear axle .....	Semi-floating
	Front : Fixed to the front frame
	Rear : Center pivot
Reduction and differential gear .....	Two stage reduction with torque proportioning differential
Oscillation angle .....	±12° ; total 24°
Final drives .....	Heavy duty, planetary final drive



## TIRES (tubeless, nylon body)

Standard .....	17.5-25-12PR (L2)
Optional .....	Refer to standard & optional equipment list.



## BRAKES

Service brake ..• Inboard mounted fully hydraulic 4 wheel wet disc brake.  
 • HST(Hydro Static Transmission) system provides additional hydraulic braking capacity.

Parking brake ... Spring applied, hydraulically released, wet disc type with drive through prevention mechanism.



## STEERING SYSTEM

Type .....	Articulated frame steering
Steering mechanism .....	Fully hydraulic power steering with orbitrol
Steering angle .....	Each direction 40° ; total 80°
Relief pressure .....	17.2 MPa (175 kgf/cm <sup>2</sup> )
Cylinders .....	Two double-acting piston type
No. x Bore x Stroke .....	2 x 55 mm x 395 mm
Minimum turning radius at the centerline of outside tire .....	4.69 m



## HYDRAULIC SYSTEM

Arm and bucket are controlled by mechanical single control lever	
Arm controls .....	Four position valve ; Raise, hold, lower, float
Bucket controls with automatic bucket return-to-dig controls .....	Three position valve ; Roll back, hold, dump
Main pump (Load & steer) .....	Gear type 141 L/min @2 450 min <sup>-1</sup> (rpm) at 1.47 MPa (15 kgf/cm <sup>2</sup> )
Relief pressure setting .....	20.6 MPa (210 kgf/cm <sup>2</sup> )
HST charging pump .....	Gear type 47L /min @2 450 min <sup>-1</sup> (rpm) at 3.9 MPa (40 kgf/cm <sup>2</sup> )
Transmission charging pump .....	Gear type 26 L/min @2 450 min <sup>-1</sup> (rpm) at 1.77 MPa (18 kgf/cm <sup>2</sup> )
Hydraulic cylinders	
Type .....	Two arm and one bucket, double acting type
No. x Bore x Stroke .....	Arm : 2 x 110 mm x 681 mm Bucket : 1 x 130 mm x 431 mm
Filters .....	Full-flow 10 micron return filter in reservoir
Hydraulic cycle times	
Lift arm raise .....	5.6 s
lower .....	3.0 s
Bucket dump .....	1.2 s
Total .....	9.8 s



## SERVICE REFILL CAPACITIES

Fuel tank .....	155 L
Engine coolant .....	23 L
Engine oil .....	13 L
Front axle differential & wheel hubs .....	14 L
Rear axle differential & wheel hubs .....	14 L
Hydraulic reservoir tank .....	50 L



## DIMENSIONS & SPECIFICATIONS

Bucket type			Standard arm			High-lift arm	
			General purpose		Light material handling	General purpose	
			With bolt-on cutting edges	With bolt-on teeth	With bolt-on cutting edges	With bolt-on cutting edges	With bolt-on teeth
Bucket capacity	ISO heaped	m <sup>3</sup>	1.6	1.5	1.9	1.4	1.3
	ISO struck	m <sup>3</sup>	1.3	1.2	1.6	1.1	1.0
Bucket width		mm	2 480	2 480	2 480	2 480	2 480
Working range							
	Dumping clearance 45 degree, full height	mm	2 740	2 650	2 650	3 075	2 985
	Reach, 45 degree dump, full height	mm	1 030	1 090	1 105	1 170	1 240
	Reach, 45 degree dump, 7 ft (2.13 m) clearance	mm	1 480	1 500	1 515	1 835	1 870
	Reach with arm horizontal and bucket level	mm	2 240	2 350	2 350	2 620	2 745
	Digging depth (Horizontal digging angle)	mm	85	95	85	195	205
	Overall operating height	mm	4 675	4 665	4 770	4 910	4 910
	Overall length (Bucket on ground)	mm	6 360	6 490	6 470	6 740	6 865
	Loader clearance circle, bucket in carry position	mm	5 470	5 480	5 500	5 620	5 640
Static tipping load *	Straight	kgf	6 310	6 410	6 210	5 080	5 160
	Full 40 degree turn	kgf	5 360	5 450	5 260	4 290	4 360
Breakout force		kN (kgf)	79 (8 100)	86 (8 800)	70 (7 090)	79 (8 070)	86 (8 780)
Operating weight *		kgf	8 120	8 080	8 220	8 280	8 230

Bucket type			Standard arm with quick-coupler		
			General purpose		Light material handling
			With bolt-on cutting edges	With bolt-on teeth	With bolt-on cutting edges
Bucket capacity	ISO heaped	m <sup>3</sup>	1.4	1.3	1.6
	ISO struck	m <sup>3</sup>	1.1	1.0	1.3
Bucket width		mm	2 480	2 480	2 480
Working range					
	Dumping clearance 45 degree, full height	mm	2 595	2 510	2 585
	Reach, 45 degree dump, full height	mm	1 160	1 240	1 175
	Reach, 45 degree dump, 7 ft (2.13 m) clearance	mm	1 535	1 555	1 545
	Reach with arm horizontal and bucket level	mm	2 430	2 555	2 445
	Digging depth (Horizontal digging angle)	mm	85	95	85
	Overall operating height	mm	4 720	4 720	4 795
	Overall length (Bucket on ground)	mm	6 550	6 675	6 565
	Loader clearance circle, bucket in carry position	mm	5 545	5 570	5 550
Static tipping load *	Straight	kgf	5 370	5 460	5 370
	Full 40 degree turn	kgf	4 500	4 590	4 500
Breakout force		kN (kgf)	63 (6 450)	67 (6 880)	62 (6 320)
Operating weight *		kgf	8 530	8 480	8 560

Notes: 1. All dimensions, weight and performance data based on ISO 6746-1:1987, ISO 7131:1997 and ISO 7546:1983

2. Static tipping load and operating weight marked with \* include 17.5-25-12PR (L2) tires (No ballast) with lubricants, coolant, full fuel tank and operator.  
Machine stability and operating weight depend on counterweight, tire size and other attachments.

Tires and Options	Change in operating weight	Change in tipping load	
		Straight	Full turn
	kg	kg	kg
17.5-25-12PR (L2) Bias ply	0	0	0
17.5-25-12PR (L3) Bias ply	88	63	55
18.4-24-10PR (L2) Bias ply	- 23	- 17	- 15
ROPS/FOPS canopy (In lieu of FRP roof canopy)	210	210	200
Steel cab (In lieu of FRP roof canopy )	270	240	230
ROPS/FOPS cab (In lieu of FRP roof canopy)	490	465	440
Lumber and pallet fork (Pin on type)*1	805	- 1 510	- 1 325
Lumber and pallet fork (For quick coupler)*1	1 140	- 1 850	- 1 650
Log grapple (Pin on type)*2	960	505	365
Counterweight, CW*028	280	610	510
Counterweight, CW*063	630	1 400	1 180

Note: \*1 CW\*063

\*2 CW\*063, 17.5-25-12PR (L2) Tires



## BUCKET SELECTION GUIDE

			Bucket Capacity	Material density kg/m <sup>3</sup>				
				1 000	1 200	1 400	1 600	1 800
Standard arm	General purpose	With bolt-on cutting edges	1.6 m <sup>3</sup>					
		With bolt-on teeth	1.5 m <sup>3</sup>					
	Light material handling	With bolt-on cutting edges	1.9 m <sup>3</sup>					
High-lift arm	General purpose	With bolt-on cutting edges	1.4 m <sup>3</sup>					
		With bolt-on teeth	1.3 m <sup>3</sup>					
Standard arm with quick-coupler	General purpose	With bolt-on cutting edges	1.4 m <sup>3</sup>					
		With bolt-on teeth	1.3 m <sup>3</sup>					
	Light material handling	With bolt-on cutting edges	1.6 m <sup>3</sup>					

% Bucket Fill Factor

## STANDARD & OPTIONAL EQUIPMENT

<b>ENGINE</b> Coolant recovery tank ● Fan safety guard (360° Full Fan Guard) ● Muffler, under hood with large exhaust stack ● Environmentally friendly engine oil drain ● Engine oil cooler ● Quick-release fuel filter and water separator ● Glow system (For cold start) ● Air filter double elements □ Air pre-cleaner □ Wide fin radiator □ Fuel double filter □	Operator warning lights: Brake oil / Engine oil pressure / Alternator voltage (Charge) ● Indicator lights: Turn signals / Warning flashers / High beam of driving light / Work lights / Park brake / High gear ● Indicator lights: Emergency steering (If Emergency steering is equipped) ● 24 volt AM/FM stereo radio with clock (For cab model only) □ 24 volt AM/FM stereo radio with cassette player and clock (For cab model only) □ Radio-ready cab, fused 24 volt radio electrical lead, speaker (1), and antenna* □ (For cab model only) Ride control system (APS: Anti-Pitching System) □	<b>BUCKETS AND ATTACHMENTS</b> Full line of Hitachi pin on buckets with selection of bolt-on cutting edges, and bolt-on teeth* ● General purpose bucket with bolt on cutting edges: 1.6 m <sup>3</sup> (ISO heaped) ● General purpose bucket with bolt on teeth: 1.5 m <sup>3</sup> (ISO heaped) □ Light material handling bucket with bolt on cutting edges: 1.9 m <sup>3</sup> (ISO heaped) □ Quick-coupler and hydraulic control system for quick-coupler locking pins, including all controls in the cab, lines, and valves □ Full line of Hitachi buckets for quick coupler with selection of bolt-on cutting edges, and bolt-on teeth* □ General purpose bucket with bolt on cutting edges: 1.4 m <sup>3</sup> (ISO heaped) □ General purpose bucket with bolt on teeth: 1.3 m <sup>3</sup> (ISO heaped) □ Light material handling bucket with bolt on cutting edges: 1.6 m <sup>3</sup> (ISO heaped) □ Full line of construction utility forks, pallet forks, and attachments* □ Lumber and pallet fork: Max load 3 200 kg (Pin on type) □ Lumber and pallet fork: Max load 2 700 kg (For quick coupler) □ Log grapple: Max load 3 900 kg (Pin on type) □
<b>POWER TRAIN</b> Hydrostatic (HST) transmission, electronic shift control, twist-grip lever, hydrostatic oil cooler, inching pedal, and two speeds forward and reverse ● QSS (Quick Shift Switch) ● Torque proportioning differentials, front and rear ●	<b>OPERATOR'S STATION</b> Canopy ● FRP roof / Multiplane isolation mount for noise/vibration reduction ● ROPS** / FOPS*** / Multi-plane isolation mounted for noise/vibration reduction □ Cab ● Steel cab (Without ROPS / FOPS) / Multi-plane isolation mounted for noise / vibration reduction / Front and rear windshield washers / Safety grass ● ROPS** / FOPS*** / Multi-plane isolation mounted for noise/vibration reduction / Front and rear windshield washers / Safety grass □ Sun visor □ Heater / Defroster (Front) (Cab model only & standard for cab model) ● Defroster (Rear side) (Cab model only) ● Air conditioning (Factory or dealer installed) ● Seat belt, 50 mm □ Seat belt, 76 mm, with retractor* □ Seat; vinyl covered , adjustable for fore-aft position, backrest tilt ● Seat; vinyl covered , mechanical suspension, adjustable for weight-height, fore-aft position, backrest tilt ● Seat; fabric covered, high back, air suspension, adjustable for weight-height, fore-aft position, backrest tilt (Cab model only) ● Seat backrest extension* (For fabric seat) ● Left door pocket for operator's manual and other items (Cab model only) ● Rubber floor mat (Cab model only) ● Steering wheel, textured with spinner knob ● Rear view mirrors, outside (2) ● Handholds, steps, and slip resistant ●	<b>TIRES</b> - Bias ply: 17.5-25-12PR (L2) ● 17.5-25-12PR (L3) □ 18.4-24-10PR (L2) □ - Radial ply: 17.5R25 (L2 type) □ 17.5R25 (L3 type) ● Single-piece rims ● Multi-piece rims* □
<b>HYDRAULIC SYSTEM</b> Automatic bucket return-to-dig control ● Automatic arm height kickout control □ Reservoir sight gauge ● Hydraulic filters, vertical mounting ● Two-function hydraulic valve with joystick control (Mechanical controlled) ● Three-function hydraulic valve with joystick control and auxiliary lever for third function (Mechanical controlled) □ Ride control, automatic type □	<b>LOADER LINKAGE</b> Z-bar loader linkage provides (High bucket breakout) ● High-lift arm □	<b>OTHERS</b> Anti-vandal protection, includes lockable engine enclosure, and fuel fill ● Counterweight, built-in ● Counterweight, extra duty* □ Drawbar, with locking pin □ Bottom guards, front frame and transmission □ Lift and tie-down hooks ● Fire extinguisher (Dealer installed) □ Emergency steering* □ Open type rear grill* ● Tropical package* (For the hot weather condition) □ Logging package* □
<b>ELECTRICAL</b> 24 volt electrical system ● Standard batteries (2), 12 volt with 582 CCA, 133-min. rated reserve ● High-capacity batteries (2), 12 volt with 782 CCA, 170-min. rated reserve ● Alternator, 50 amps and 24 volts ● Alternator, high capacity, 60 amps and 24 volts ● Lights ● Driving with guards / Turn signals and flashers / Stops, tail and back-up lights / Conform to SAE 99 ● Work lights on cab, front (2) (Cab model only) ● Work lights, rear (2) ● Push-button horn in center of steering wheel ● Reverse warning alarm ● Monitor and alarm system, multi-function Electronic ● Audible and visual warning include Analog instruments: Engine coolant temperature / Fuel level / Speedometer ● Digital instrument: Hour-meter ●		

Note: ● Standard equipment □ Optional or special equipment

\* : Please consult your Hitachi dealer for further information

\*\* : ROPS (Roll Over Protective Structure) Conforms to ISO 3471;1994

\*\*\* : FOPS (Falling Objects Protective Structure) Conforms to ISO 3449; 1992 Level II

 **Hitachi Construction Machinery Co., Ltd.**

**Head Office:** 5-1 Koraku 2-chome, Bunkyo-ku,  
Tokyo 112-8563, Japan

**Telephone:** (03)3830-8050

**Facsimile:** (03)3830-8204

*These specifications are subject to change without notice.  
Illustrations and photos show the standard models, and may or may not include optional  
equipment, accessories, and all standard equipment with some differences in color and features.  
Before use, go through Operators Manual for proper operation.*

KL-E119

03.08 (KA/KA, MT<sub>3</sub>)

Printed in Japan