

LX110

HITACHI

LX110

W H E E L L O A D E R

- Engine Rated Power : 94 kW (128 PS)
- Operating Weight : 10 090 kg
- Bucket Capacity : ISO Heaped
1.5 m³ – 2.3 m³

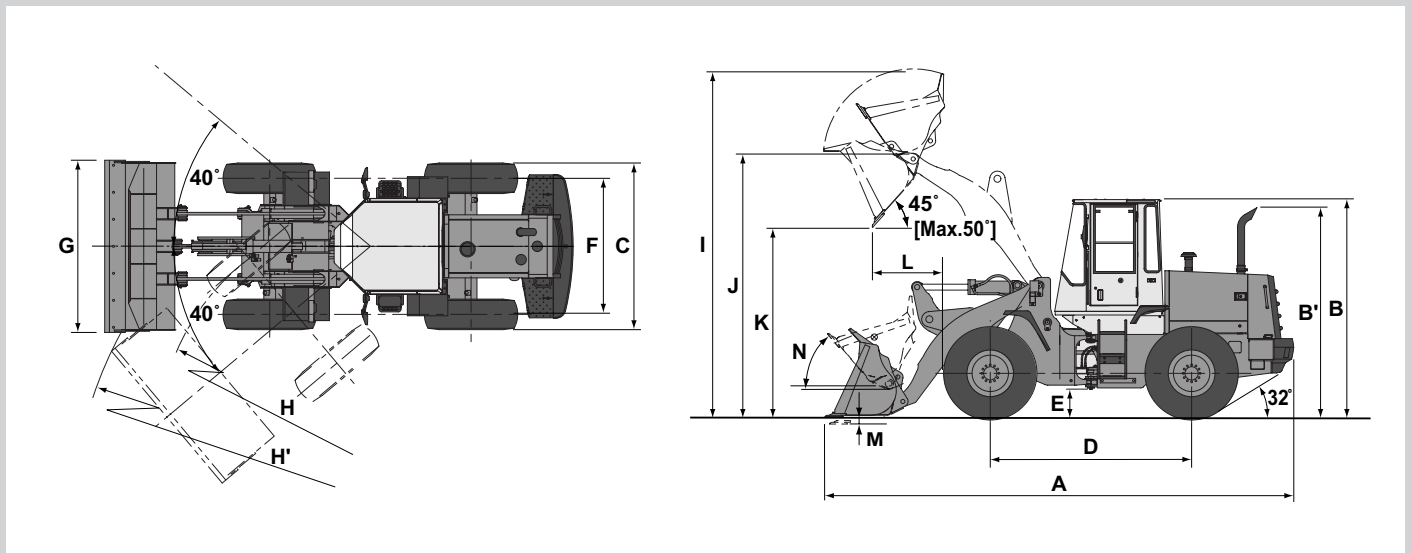

Unit : mm

	LX110-7
A Overall length	6 750
B Height to top of cab	3 140
B' Height to top of exhaust	3 050
C Width over tires	2 410
D Wheel base	2 900
E Ground clearance	400
F Tread	1 960
G Bucket width	2 480
H Turning radius (Centerline of outside tire)	4 990
H' Loader clearance circle, bucket in carry position	5 720
I Overall operating height	5 015
J Height to bucket hinge pin, fully raised	3 715
K Dumping clearance 45 degree, full height	2 760
L Reach, 45 degree dump, full height	1 070
Reach, 45 degree dump, 7 ft (2.13 m) clearance	1 535
M Digging depth (Horizontal digging angle)	100
N Max. roll back at carry position	50 deg.
Tire size	17.5 - 25 - 12PR (L3)

Note: General purpose bucket with bolt on cutting edges.



ENGINE

Model Isuzu BB-6BG1T
 Type 4-cycle water-cooled, direct injection
 Aspiration Turbocharger
 No. of cylinders 6
 Rated power
 DIN 6 271, net 94 kW (128 PS) at 2 200 min⁻¹ (2 200 rpm)
 SAE J1349, net 96 kW (128 hp) at 2 200 min⁻¹ (2 200 rpm)
 Bore and stroke 105 mm x 125 mm
 Piston displacement 6.494 L
 Electrical system 24 volt with 0.96 kW, 50 A alternator
 Starting system 24 V x 4.5 kW electric motor.
 Batteries 2 x 12 V / 512 CCA, 182-min. rated reserve
 Air cleaner Single element dry type with restriction indicator



POWER TRAIN

Transmission Torque converter ; countershaft type powershift
 with electrically controlled.
 Torque converter Three element, single stage, single phase
 Main clutch Wet hydraulic, multi-disc type
 Cooling method Forced circulation type
 Travel speed* : km/h

	Forward / Reverse
1st	8.0 / 8.5
2nd	13.5 / 14.5
3rd	21.5 / 23.0
4th	34.5 / 35.0

* With 17.5-25-12PR (L3) tires



AXLE AND FINAL DRIVE

Drive system Four-wheel drive system
 Front & rear axle Semi-floating
 Front : Fixed to the front frame
 Rear : trunnion support
 Reduction and differential gear Two stage reduction with torque
 proportional differential
 Oscillation angle ± 12° ; total 24°
 Final drives Heavy-duty planetary, mounted inboard



TIRES (tubeless, nylon body)

Standard 17.5-25-12PR (L3)
 Optional Refer to standard & optional equipment list.



BRAKES

Service brakes Inboard mounted fully hydraulic 4 wheel wet disc brake.
 Front & rear independent brake circuit.
 Parking brake Spring applied hydraulic released wet disc type with drive
 through prevention mechanism.



STEERING SYSTEM

Type Articulated frame steering
 Steering mechanism Full hydraulic power steering with orbitrol
 Steering angle Each direction 40° ; total 80°
 Relief pressure 17.2 MPa (175 kgf/cm²)
 Cylinders Two double-acting piston type
 No. x Bore x Stroke 2 x 60 mm x 395 mm
 Minimum turning radius at
 the centerline of outside tire 4.99 m



HYDRAULIC SYSTEM

Arm and bucket are controlled by mechanical single control lever
 Arm controls Four position valve ; Raise, hold, lower, float
 Bucket controls with automatic bucket
 return-to-dig control Three position valve ; Roll back, hold, dump
 Steering pump
 (Load & steer) Gear type 124 L/min
 @2 550 min⁻¹ (rpm) at 981 KPa (10 kgf/cm²)
 Main pump
 (Load) Gear type 52 L/min
 @2 550 min⁻¹ (rpm) at 981 KPa (10 kgf/cm²)
 Relief pressure setting 20 590 KPa (210 kgf/cm²)
 Charging pump Double gear type with two discharge ports
 Front pump Front 87 L/min
 @2 380 min⁻¹ (rpm) at 2 160 KPa (22 kgf/cm²)
 Rear pump
 (brake pump) Rear 38 L/min
 @2 380 min⁻¹ (rpm) at 200 KPa (2 kgf/cm²)
 Hydraulic cylinders
 Type Two arm and one bucket, double acting type
 No. x Bore x Stroke Arm : 2 x 120 mm x 665 mm
 Bucket : 1 x 150 mm x 431 mm
 Filters Full-flow 15 micron return filter in reservoir
 Hydraulic cycle times
 Lift arm raise 5.9 s
 lower 3.0 s
 Bucket dump 1.4 s
 Total 10.3 s
 Fuel tank 170 L
 Engine coolant 31 L
 Engine oil 13 L
 Front axle differential & wheel hubs 21 L
 Rear axle differential & wheel hubs 21 L
 Torque convertor & transmission 20 L
 Hydraulic reservoir 80 L



SERVICE REFILL CAPACITIES



DIMENSIONS & SPECIFICATIONS

Bucket type			Standard arm			High-lift arm	
			General purpose		Light material handling	General purpose	
			With bolt-on cutting edges	With bolt-on teeth	With bolt-on cutting edges	With bolt-on cutting edges	With bolt-on teeth
Bucket capacity	ISO heaped	m ³	2.0	1.9	2.3	1.6	1.5
	ISO struck	m ³	1.7	1.6	2.0	1.3	1.3
Bucket width		mm	2 480	2 480	2 480	2 480	2 480
Working range							
	Dumping clearance 45 degree, full height	mm	2 760	2 670	2 650	3 190	3 095
	Reach, 45 degree dump, full height	mm	1 070	11 50	1 190	1 170	1 245
	Reach, 45 degree dump, 7 ft (2.13 m) clearance	mm	1 535	1 560	1 585	1 920	1 955
	Reach with arm horizontal and bucket level	mm	2 320	2 360	2 470	2 770	2 900
	Digging depth (Horizontal digging angle)	mm	100	110	100	245	260
	Overall operating height	mm	5 015	5 015	5 015	5 160	5 160
	Overall length (Bucket on ground)	mm	6 750	6 870	6 910	7 140	7 270
	Loader clearance circle, bucket in carry position	mm	5 720	5 760	5 810	5 900	5 940
Static tipping load *	Straight	kgf	7 900	7 950	7 800	6 050	6 100
	Full 40 degree turn	kgf	6 800	6 900	6 960	5 350	5 400
Breakout force		kN	98	105	84	105	113
		(kgf)	(10 000)	(10 700)	(8 600)	(10 700)	(11 500)
Operating weight *		kgf	10 090	10 030	10 150	10 270	10 230

Bucket type			Standard arm with quick-coupler	
			General purpose	
			With bolt-on cutting edges	With bolt-on teeth
Bucket capacity	ISO heaped	m ³	1.6	1.5
	ISO struck	m ³	1.3	1.3
Bucket width		mm	2 480	2 480
Working range				
	Dumping clearance 45 degree, full height	mm	2 640	2 550
	Reach, 45 degree dump, full height	mm	1 190	1 265
	Reach, 45 degree dump, 7 ft (2.13 m) clearance	mm	1 590	1 610
	Reach with arm horizontal and bucket level	mm	2 555	2 680
	Digging depth (Horizontal digging angle)	mm	100	110
	Overall operating height	mm	4 850	4 850
	Overall length (Bucket on ground)	mm	6 895	6 990
	Loader clearance circle, bucket in carry position	mm	5 805	5 845
Static tipping load *	Straight	kgf		
	Full 40 degree turn	kgf		
Breakout force		kN		
		(kgf)		
Operating weight *		kgf	10 460	10 420

Notes: 1. All dimensions, weight and performance data based on ISO 6746-1:1987, ISO 7131:1997 and ISO 7546:1983

2. Static tipping load and operating weight marked with * include 17.5-25-12PR (L3) tires (No ballast) with lubricants, coolant, full fuel tank and operator. Machine stability and operating weight depend on counterweight, tire size and other attachments.

Tires and Options	Change in operating weight	Change in tipping load	
		Straight	Full turn
	kg	kg	kg
17.5-25-12PR (L2) Bias ply	- 88	- 40	- 40
17.5 R25 (L2 type) Radial ply	- 12	0	0
17.5 R25 (L3 type) Radial ply	128	110	100
17.5 R25 (L5 type) Radial ply	—	—	—
FRP roof canopy (In lieu of ROPS/FOPS cab)	- 450	- 420	- 380
ROPS/FOPS canopy (In lieu of ROPS/FOPS cab)	- 240	- 190	- 170
Steel cab (In lieu of ROPS/FOPS cab)	- 180	- 170	- 150
Lumber and pallet fork (Pin on type)	—	—	—
Lumber and pallet fork (For quick coupler)	—	—	—
Log grapple (Pin on type)*	860	210	190
Counterweight, CW*155	470	1 960	930

Note: * With counterweight CW*155 and 17.5-25-12PR (L2) tires



BUCKET SELECTION GUIDE

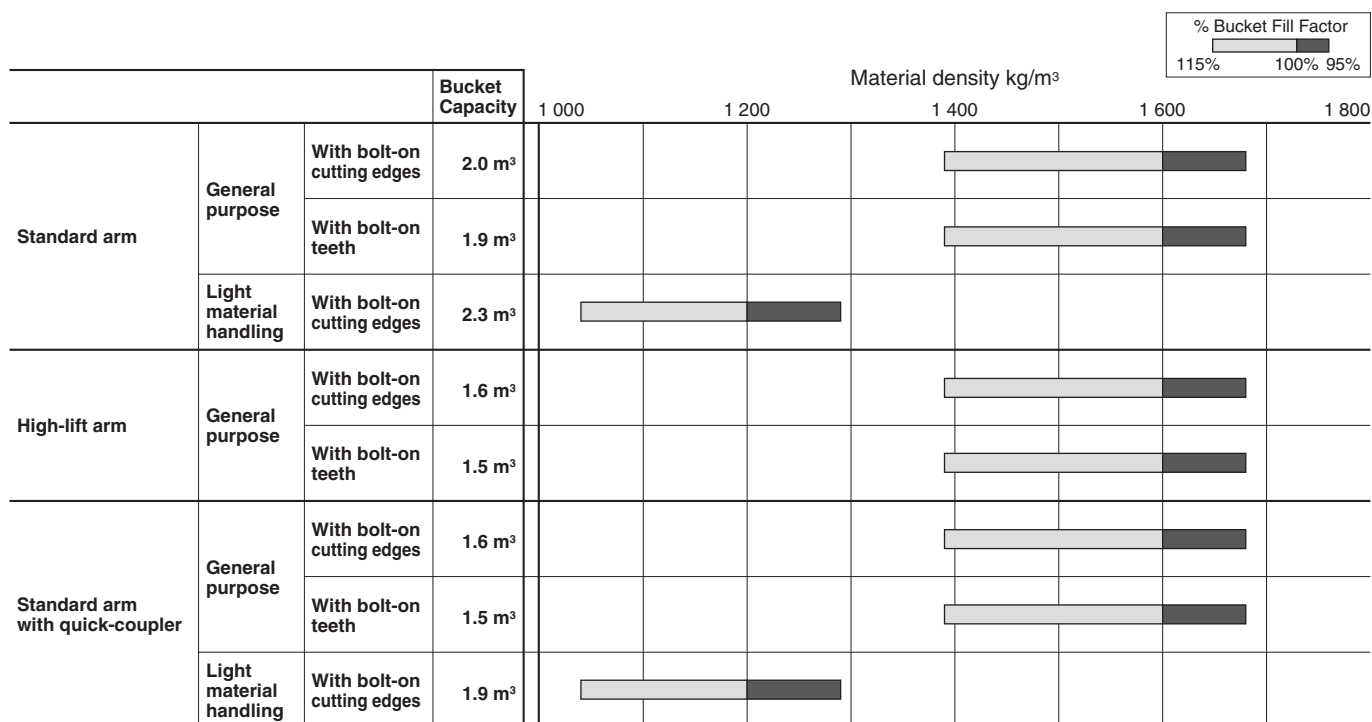

STANDARD & OPTIONAL EQUIPMENT

ENGINE	<ul style="list-style-type: none"> ● Coolant recovery tank ● Fan safety guard (360° Full Fan Guard) ● Muffler, under hood with large exhaust stack ● Environmentally friendly engine oil drain ● Engine oil cooler ● Quick-release fuel filter and water separator ● Glow system (For cold start) ● Air filter double element □ Air pre-cleaner □ Wide fin radiator □ Fuel double filter 	<ul style="list-style-type: none"> ● Monitor and alarm system, multi-function electronic Audible and visual warning include ● Analog instruments: Engine coolant temperature / Transmission oil temperature / Fuel level / Speedometer ● Digital instrument: Hour-meter ● Operator warning lights: Brake pressure / Brake oil / Engine oil pressure / Alternator voltage (Charge) □ Indicator lights: Turn signals / Warning flashers / High beam of driving light / Work lights / Park brake / Clutch cut off □ Indicator lights: Emergency steering (If Emergency steering is equipped) □ Indicator lights: Gear shift (If Automatic shift transmission is equipped) □ 24-volt AM/FM stereo radio with clock (Cab model only) ● 24-volt AM/FM stereo radio with cassette player and clock (Cab model only) ● Radio-ready cab, fused 24-volt radio electrical lead, speaker (1), and antenna* 	<ul style="list-style-type: none"> ● LOADER LINKAGE ● Z-bar loader linkage provides (High bucket breakout) ● High-lift arm*
POWER TRAIN	<ul style="list-style-type: none"> ● TC/PS transmission, electrically-controlled manual shift features included □ TC/PS transmission, computer-controlled automatic shift and manual shift features included ● DSS (Down Shift Switch) ● Torque proportioning differentials, front and rear 	<ul style="list-style-type: none"> □ 24-volt AM/FM stereo radio with clock (Cab model only) ● 24-volt AM/FM stereo radio with cassette player and clock (Cab model only) ● Radio-ready cab, fused 24-volt radio electrical lead, speaker (1), and antenna* 	<ul style="list-style-type: none"> ● BUCKETS AND ATTACHMENTS ● Full line of Hitachi pin on buckets with selection of bolt-on cutting edges, and bolt-on teeth* ● General purpose bucket with bolt on cutting edges : 2.0 m³ (ISO heaped) □ General purpose bucket with bolt on teeth: 1.9 m³ (ISO heaped) □ Light material handling bucket with bolt on cutting edges : 2.3 m³ (ISO heaped) □ Quick-coupler and hydraulic control system for quick-coupler locking pins, includes all controls in the cab, lines, and valves □ Full line of Hitachi buckets for quick coupler with selection of bolt-on cutting edges, and bolt-on teeth* □ General purpose bucket with bolt on cutting edges : 1.6 m³ (ISO heaped) □ General purpose bucket with bolt on teeth: 1.5 m³ (ISO heaped) □ Light material handling bucket with bolt on cutting edges : 1.9 m³ (ISO heaped) □ Full line of construction utilityforks, pallet forks, and attachments* □ Lumber and pallet fork : Max load 3 800 kg (Pin on type) □ Lumber and pallet fork : Max load 3 200 kg (For quick coupler) □ Log grapple : Max load 4 700 kg (Pin on type)
HYDRAULIC SYSTEM	<ul style="list-style-type: none"> ● Automatic bucket return-to-dig control □ Automatic arm height kickout control ● Reservoir sight gauge ● Hydraulic filters, vertical mounting ● Two-function hydraulic valve with joystick control (Mechanical controlled) □ Two-function hydraulic valve with joystick control (Pilot controlled) □ Two-function hydraulic valve with two levers (Pilot controlled) □ Three-function hydraulic valve with joystick control and auxiliary lever for third function (Mechanical controlled) □ Three-function hydraulic valve with two levers control and auxiliary lever for third function (Pilot controlled) □ Adjustable wristrest for two levers control □ Ride control, automatic type 	<ul style="list-style-type: none"> ● OPERATOR'S STATION ● Canopy □ FRP roof / Multiplane isolation mount for noise/vibration reduction ● ROPS** / FOPS*** / Multi-plane isolation mounted for noise/vibration reduction □ Cab □ Steel Cab (Without ROPS / FOPS) / Multi-plane isolation mounted for noise/vibration reduction / Front and rear windshield washers / Safety grass □ ROPS** / FOPS*** / Multi-plane isolation mounted for noise/vibration reduction / Front and rear windshield washers / Safety grass □ Sun visor □ Heater / Defroster (Cab model only) □ Less Heater & Defroster (Cab model only)* □ Air conditioning (Factory or dealer installed) ● Seat belt, 50 mm ● Seat belt, 76 mm, with retractor* ● Seat, fabric covered , high back, mechanical suspension, adjustable for weight-height, fore-aft position, backrest tilt, and armrest angle □ Seat, vinyl covered , mechanical suspension, adjustable for weight-height, fore-aft position, backrest tilt* ● Seat, fabric covered, high back, air suspension, adjustable for weight-height, fore-aft position, backrest tilt, and armrest angle* ● Seat backrest extension (For fabric seat) ● Left door pocket for operator's manual and other items ● Rubber floormat ● Steering wheel, textured with spinner knob ● Rear view mirrors, outside (2) and inside (1) ● Handholds, steps, and slip resistant 	<ul style="list-style-type: none"> ● TIRES ● Bias ply : <ul style="list-style-type: none"> □ 17.5-25-12 PR (L2) ● 17.5-25-12 PR (L3) □ Radial ply : <ul style="list-style-type: none"> □ 17.5R25 (L2 type) ● 17.5R25 (L3 type) □ 17.5R25 (L5 type) ● Single-piece rims □ Multi-piece rims*
ELECTRICAL	<ul style="list-style-type: none"> ● 24-volt electrical system ● Standard batteries (2), 12 volt with 512 CCA, 182-min. rated reserve □ High-capacity batteries (2), 12 volt with 1045 CCA, 304-min. rated reserve ● Alternator, 50 amps and 24 volts ● Alternator, high capacity, 60 amps and 24 volts ● Lights <ul style="list-style-type: none"> ● Driving with guards / Turn signals and flashers / Stop, tall and back-up lights ● Work lights on cab, front (2) (Cab model only) ● Work lights, rear (2) ● Push-button horn in center of steering wheel ● Reverse warning alarm 	<ul style="list-style-type: none"> □ OTHERS ● Fenders, front and rear ● Articulation locking bar □ Anti-vandal protection, includes lockable engine enclosure, and fuel fill ● Counterweight, built-in □ Counterweight, extra duty* ● Drawbar, with rocking pin □ Bottom guards, front frame and transmission ● Lift and tie-down hooks ● Fire extinguisher (Dealer installed) □ Emergency steering* □ Open type rear grill* □ Tropical pack* (For the hot weather condition) 	

Note: ● Standard equipment □ Optional or special equipment

* : Please consult your Hitachi dealer for further information

** : ROPS (Roll Over Protective Structure) Conforms to ISO 3471;1994

*** : FOPS (Falling Objects Protective Structure) Conforms to ISO 3449; 1992 Level II

 **Hitachi Construction Machinery Co., Ltd.**

Head Office: 5-1 Koraku 2-chome, Bunkyo-ku,
Tokyo 112-8563, Japan

Telephone: (03)3830-8050

Facsimile: (03)3830-8204

*These specifications are subject to change without notice.
Illustrations and photos show the standard models, and may or may not include optional
equipment, accessories, and all standard equipment with some differences in color and features.
Before use, go through Operators Manual for proper operation.*

KL-E120

'03.08 (KA/KA, MT₃)

Printed in Japan